

# THE LOSS OF ONE-SIDED LINK SYSTEMS WITH SHORT PATH CONNECTIONS

A. RÖDER

Institute of Switching and Data Technics, University of Stuttgart,  
Stuttgart, Federal Republic of Germany

## ABSTRACT

In one-sided link systems, the use of short path connections leads to an increase of the grade of service. For such systems with three stages an approximate loss calculation method is presented. Hereby the two different selection modes point-to-point selection as well as point-to-group selection are considered. The calculation results have been checked by simulation.

## 1. INTRODUCTION

In a one-sided link system (reversed link system) all terminations (subscribers, trunks, etc.) are connected to only one side of the switching array. The outlets on the other side are looped among themselves, thus a connection through such a system requires two paths (one loop). This type of link system is used in the switching network of the system EWS (Elektronisches Wähl-system) of the Deutsche Bundespost. For certain one-sided link systems it is necessary and economic to make use of so-called short path connections.

Fig. 1 shows a 3-stage one-sided link system. For reasons of clarity, only multiples with 2 inlets and 2 outlets are plotted. The stages A and B are wired in link blocks each having 2 multiples. Two of these link blocks form, together with 4 multiples of the C stage, one ABC group of link blocks. The system itself consists of 3 ABC groups of link blocks. The outlets of the last stage (stage C) are wired in such a manner that always the two other ABC groups of link blocks can be accessed. In this example all 4 types of connections are drawn:

### Short path connection A:

Calling and called terminations are located at the same multiple of stage A. For this connection two crosspoints are used and consequently one link between stage A and B becomes busy.

### Short path connection B:

The two considered terminations are located at different multiples but within the same AB-link block. A connection has to be set up from the calling termination via a link between stage A and B to a multiple in stage B. There the reversal takes place and the path leads back to the destination multiple in the A stage where the called termination is located. Here, 4 crosspoints are used and one link between stage B and C becomes busy.

### Short path connection C:

The two considered terminations are located at different AB link blocks, but within the same ABC group of link blocks. The reversal takes place in stage C and 6 crosspoints are used. One link behind stage C (one loop) becomes busy.

### Normal connection:

The two considered terminations are located at different ABC groups of link blocks. In this case, two paths through the system and one loop (behind stage C) are used (6 crosspoints).

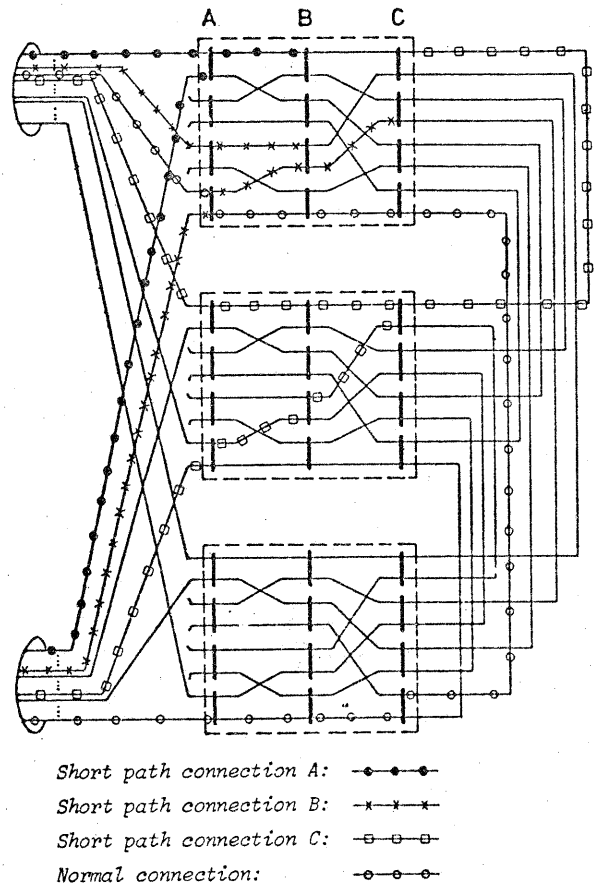

Fig. 1: One-sided link system with short path connections

Fig. 2 shows a multiple with 4 inlets and 4 outlets. If a connection is reversed in this multiple two inlets have to be connected. Therefore, two crosspoints are closed and one of the outlets becomes busy.

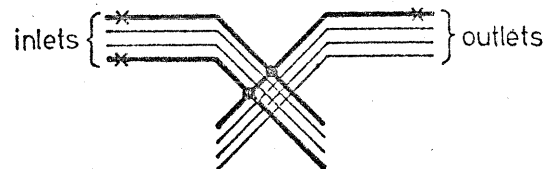

Fig. 2: Reversal within a multiple

Throughout this paper the following structural short notations will be applied:

- $i_A, i_B, i_C$  - inlets per multiple in stage A, B, C
- $k_A, k_B, k_C$  - outlets per multiple in stage A, B, C
- $\varepsilon_{1A}, \varepsilon_{1B}$  - number of multiples of a link block in stage A and B
- $\varepsilon_{gA}, \varepsilon_{gB}, \varepsilon_{gC}$  - number of multiples of a group of ABC link blocks in stage A, B and C
- $\varepsilon_A, \varepsilon_B, \varepsilon_C$  - number of multiples in stage A, B, C.

WEITERVERWENDUNG NUR MIT QUELLENGABE!

Fig. 3 shows the applied notations for a complete one-sided link system.



Fig. 3: Short notation for a one-sided link system

The following Chapter with the carried traffic on the links using short path connections. Chapters 3 and 4 show calculation for systems as well as point-to-point selection mode. Hereby the formulae are selected to systems without concentration at stage  $(i \leq k)$ . In Chapter 5 systems with concentration are considered as well as systems with different trunk group sizes and different carried traffics per group. The comparison of calculation and simulation is shown in the last Chapter.

## 2. CARRIED TRAFFIC ON LINKS

Using short path connections leads to different values of the carried traffic on the links between the stages A-B and C-C of the system. In Fig. 4 this fact is shown. The vertical bars represent all multiples in stages A, B and C of all ABC groups of link blocks.

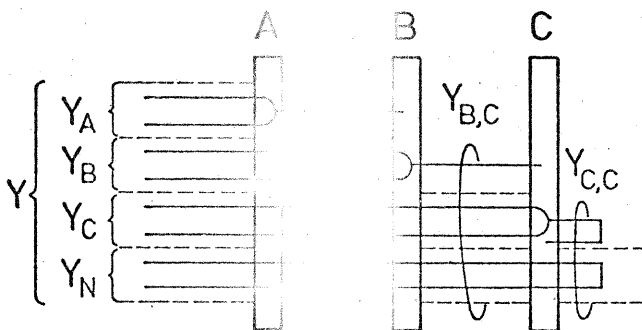

Fig. 4: Carried traffic on links

The prescribed carried terminations (inlets/outlets) on the system can be partitioned into  $Y_A, Y_B, Y_C$  and  $Y_N$ , i.e. carried traffic caused by short path connections A, B, C as well as normal connections.

It holds

$$Y = Y_A + Y_B + Y_C + Y_N \quad (1)$$

Therewith we obtain the carried traffic on all links between the stages (Fig. 4):

$$Y_{A,B} = Y - Y_A \quad (2a)$$

$$Y_{B,C} = Y - Y_A - Y_N \quad (2b)$$

$$Y_{C,C} = Y - Y_A - Y_N \quad (2c)$$

In order to calculate the probabilities of  $Y_A, Y_B, Y_C$  and  $Y_N$  we introduce the "connection probabilities"  $P_A, P_B, P_C$  and  $P_N$ . These probabilities are defined whether an offered call is connected via a short path A, B or C or via a normal path, resp.

Thus we obtain

$$Y_j = Y \cdot \frac{P_j}{P_A + P_B + P_C + P_N} \quad (j=A, B, C, N) \quad (3)$$

The denominator in this equation expresses the fact, that here the connection probabilities  $P_A, P_B, P_C$  and  $P_N$  have to be referred to the established calls (and not to the offered ones). In other words the denominator corresponds to the probability, that an offered call is successful. Thus we obtain the loss probability B

$$B = 1 - (P_A + P_B + P_C + P_N) \quad (4)$$

The determination of these connection probabilities will be the topic of the following two chapters, depending on the selection modes point-to-point or point-to-group, respectively.

## 3. LOSS PROBABILITY IN THE POINT-TO-POINT SELECTION MODE

### 3.1 Definitions

We consider the point-to-point selection mode in one-sided link systems with short path connections. A call occupies an idle inlet of the system. Then, the marker a priori chooses one of the momentarily idle outlets of the desired trunk group and tries to set up a connection. If no chain of idle links through the system from inlet to outlet can be found, the considered call suffers a point-to-point loss  $B_{pp}$ . If the desired group has more than one idle outlet, the a priori selection can be realized in two different ways:

Strategy a):

the idle outlet is chosen at random, or

strategy b):

the idle outlet is chosen close by the calling inlet, i.e.

- at the same multiple of stage A, or, if there is none,
- within the same AB link block, or, if there is none,
- within the same ABC group of link blocks, or, if there is none,
- within another ABC group of link blocks.

It is obvious that the strategy b) prefers short path connections which lead to a reduction of the loss probability. As a prerequisite for the loss calculation the probabilities for the location of the calling inlet and called outlet have to be defined. Be

- $W_A$  - probability that calling and called terminations are located at the same multiple (short path connection A),
- $W_B$  - probability that the terminations are located at different multiples within the same AB link block (short path connection B),
- $W_C$  - probability that the terminations are located at different AB link blocks but within the same ABC group of link blocks (short path connection C),
- $W_N$  - probability that the terminations are located at different ABC groups of link blocks (normal connection).

For these probabilities holds

$$W_A + W_B + W_C + W_N = 1 \quad (5)$$

In case of marking strategy a) we determine the values  $W_A, W_B, W_C, W_N$  as follows:

$$\begin{aligned} W_A &= 1/g_A \\ W_B &= (g_{1A} - 1)/g_A \\ W_C &= (g_{2A} - g_{1A})/g_A \\ W_N &= (g_A - g_{2A})/g_A \end{aligned} \quad (6)$$

As to the short notation cf. Fig. 3. If  $E(k,n)$  is the probability that at least certain  $k$  out of  $n$  trunks of a considered group are busy, we obtain in case of marking strategy/b)

$$\begin{aligned} W_A &= (1-E(k_{Ar}, n_r)) / (1-E(n_r, n_r)) \\ W_B &= (E(k_{Ar}, n_r) - E(k_{Ar} \cdot g_{1A}, n_r)) / (1-E(n_r, n_r)) \\ W_C &= (E(k_{Ar} \cdot g_{1A}, n_r) - E(k_{Ar} \cdot g_{GA}, n_r)) / (1-E(n_r, n_r)) \\ W_N &= (E(k_{Ar} \cdot g_{GA}, n_r) - E(n_r, n_r)) / (1-E(n_r, n_r)) \end{aligned} \quad (7)$$

Hereby  $k_{Ar} = n_r / g_A$  denotes that number of terminations of the desired group  $r$  which are located at one multiple of stage A, and  $n_r$  the total number of trunks belonging to group  $r$ . The denominators in Equations (7) are necessary due to Equation (5).

We assume the state probabilities  $p(x)$  on the  $n_r$  trunks for a fully accessible group according to Erlang

$$p(x) = \frac{A^* x}{x!} / \sum_{j=0}^{n_r} \frac{A^* j}{j!} \quad (8)$$

where  $A^*$  has to be determined iteratively, in order to achieve the prescribed carried traffic  $Y_r$  in the considered group

$$A^* = \frac{Y_r}{1-p(n_r)} \quad (9)$$

Then we obtain the probability  $E(k,n)$  used in Equations (7)

$$E(k, n_r) = \sum_{x=k}^{n_r} p(x) \cdot \frac{\binom{x}{k}}{\binom{n_r}{k}} \quad (10)$$

If  $k_{Ar} = n_r / g_A$  is not an integer number we have to perform an interpolation. This way of calculating  $W_A$ ,  $W_B$ ,  $W_C$  and  $W_N$  implies that all trunk groups have the same size and the same carried traffic between each other. In reality these values will be different. Considering this fact the solution becomes somewhat more difficult. This will be dealt with in chapter 5. Furthermore be  $B_A$ ,  $B_B$ ,  $B_C$  and  $B_N$  the exclusive probabilities that a short path connection A, B, C or a normal connection cannot be set up (due to internal blocking).

Then we obtain the connection probabilities (cf. Equ. (3))

$$P_j = W_j \cdot (1-B_j) \quad (j=A, B, C, N) \quad (11)$$

Therewith the resulting point-to-point loss  $B_{PP}$  becomes (cf. Equ. (4))

$$\begin{aligned} B_{PP} &= 1 - (P_A + P_B + P_C + P_N) \\ &= W_A B_A + W_B B_B + W_C B_C + W_N B_N \end{aligned} \quad (12)$$

The derivation of the connection probabilities  $P_A$ ,  $P_B$ ,  $P_C$  and  $P_N$  as well as of the partial losses  $B_A$ ,  $B_B$ ,  $B_C$  and  $B_N$  will be given in the following sections.

### 3.2 Connection Probability $P_A$ for Short Path Connections A

If calling and called terminations are located at the same multiple in stage A, a short path connection A can be set up if at least one of the  $k_A$  outlets of this multiple leading to the stage B is idle. In this chapter only systems without concentration in any stage are considered ( $i \neq k$ ).

Therefore, the short path connection A can always be established and the partial loss becomes

$$B_A = 0 \quad (13)$$

By inserting this equation into Equ. (11) we obtain the connection probability  $P_A$

$$P_A = W_A \quad (14)$$

In a next step the connection probability  $P_B$  for short path connections B has to be determined. For the calculation of this probability the carried traffic  $Y_{A,B}$  of the links between stage A and B has to be known in advance.

By inserting Equ. (12), (14) and (3) into (2a) we obtain

$$Y_{A,B} = Y - Y \cdot \frac{W_A}{1-B_{PP}} \cdot \frac{1}{2} \quad (15)$$

At this point the value of the resulting point-to-point loss  $B_{PP}$  is not yet known. Therefore, the calculation must be performed iteratively.

### 3.3 Connection Probability $P_B$ for Short Path Connections B

Fig. 5a) shows the connection graph for a short path connection B. By mapping this one-sided graph into a loss-equivalent two-sided link system we obtain the 3-stage connection graph in Fig. 5b) (cf. /4/).

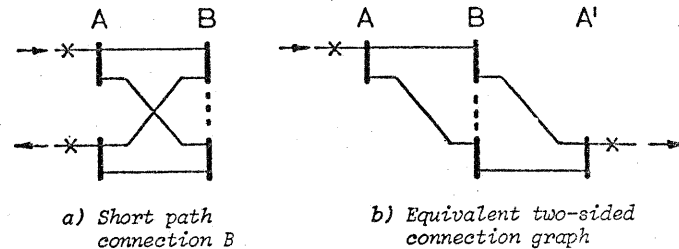

Fig. 5: Mapping of a one-sided (2-stage) connection graph into a two-sided (3-stage) one

Using the method PPL (Point-to-Point Loss) /3/) we calculate the effective accessibility of the two-sided link system. Therewith we obtain the probability  $B_B$ , that a connection cannot be set up via short path B due to internal blocking. The connection probability  $P_B$  then reads

$$P_B = W_B (1-B_B) \quad (16)$$

Therewith we determine the carried traffic  $Y_{B,C}$  between stage B and C (cf. Equ. (2b), (3), (12))

$$Y_{B,C} = Y - Y \cdot \frac{W_A}{1-B_{PP}} - Y \cdot \frac{W_B (1-B_B)}{1-B_{PP}} \cdot \frac{1}{2} \quad (17)$$

and the carried traffic  $Y_{C,C}$  behind the last stage (stage C)

$$Y_{C,C} = Y - Y \cdot \frac{W_A}{1-B_{PP}} - Y \cdot \frac{W_B (1-B_B)}{1-B_{PP}} \quad (18)$$

### 3.4 Connection Probability $P_G$ for Short Path Connections C

The mapping procedure of the 3-stage one-sided connection graph for short path connections C (cf. /4/) leads to a 5-stage two-sided connection graph (cf. Figs. 6a, 6b). Its structure is of a symmetrical type. As the PPL-calculation method published in /3/ considers only structures with interleaved link wiring (for stages  $S \geq 5$ ), an extension to symmetrical link wiring has been made in order to calculate the partial point-to-point loss  $B_C$ . A publication on this matter is under work /5/.

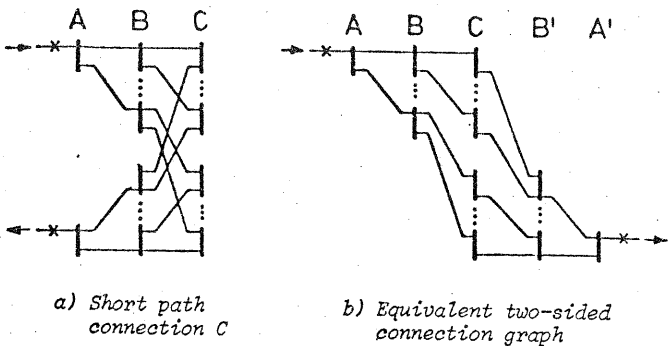

Fig. 6: Mapping of a one-sided (3-stage) connection graph into a two-sided (5-stage) one with symmetrical link wiring

We obtain the connection probability  $P_C$  for short path connections C:

$$P_C = W_C \cdot (1 - B_C) \quad (19)$$

### 3.5 Connection Probability $P_N$ for Normal Connections

The loss probability  $B_N$  for normal connections is determined by applying again the extended method PPL (cf. chapter 3.4). Fig. 7a) shows the 3-stage one-sided connection graph and Fig. 7b) the loss equivalent two-sided connection graph.

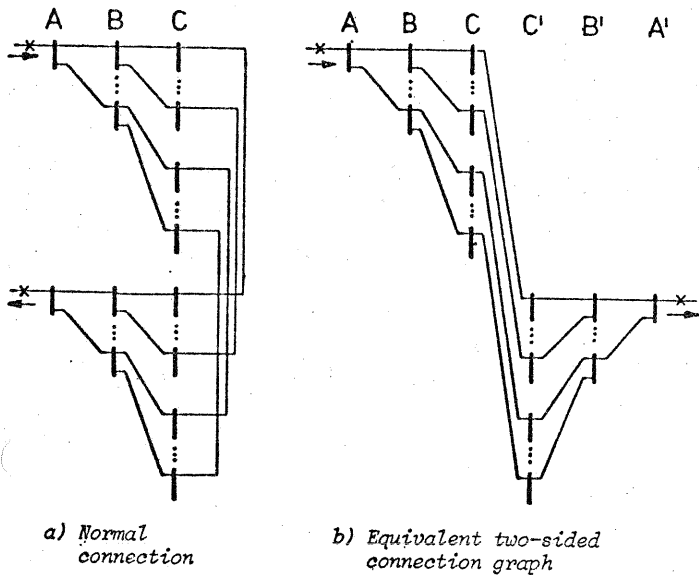

Fig. 7: Mapping of a one-sided (3-stage) connection graph into a two-sided (6-stage) one with symmetrical link wiring

Therewith the connection probability reads

$$P_N = W_N \cdot (1 - B_N) \quad (20)$$

### 3.6 Point-to-Point Loss $B_{PP}$

As already shown in Equ. (12) the point-to-point loss  $B_{PP}$  now becomes

$$B_{PP} = W_{B'B} + W_{C'C} + W_{N'N} \quad (21)$$

## 4 LOSS PROBABILITY IN THE POINT-TO-GROUP SELECTION MODE

### 4.1 Definition

A call occupies an idle inlet of the system. The marker tries to set up a connection from this inlet to the desired group. Hereby it preferably tries to find a short path connection A. If this is not possible further attempts are made in the sequence via short path B, via short path C and finally via normal path. If all trunks of the desired group are momentarily busy, or if no connection to any idle trunk can be set up due to internal blocking, a considered call suffers a point-to-group loss  $B_{PG}$ .

### 4.2 Connection Probability $P_A$ for Short Path Connections A

A short path connection A is always possible if the multiple in stage A, where the calling termination is connected to, has at least one idle trunk belonging to the desired group. Assuming an Erlang distribution on the  $n_r$  trunks of the desired group r the connection probability  $P_A$  becomes

$$P_A = 1 - E(k_{Ar}, n_r) \quad (22)$$

For the short notations cf. Equations (8) to (10). Thus we calculate the carried traffic  $Y_{A,B}$  between stage A and B by using Equ. (3) and (2a)

$$Y_{A,B} = Y - Y \cdot \frac{1 - E(k_{Ar}, n_r)}{1 - B_{PG}} \cdot \frac{1}{2} \quad (23)$$

Like in the case of point-to-point selection, the resulting point-to-group loss  $B_{PG}$  is not yet known. Again an iterative calculation is applied.

### 4.3 Connection Probability $P_B$ for Short Path Connections B

In Fig. 8a) the one-sided connection graph for a short path connection B is drawn. The mapped two-sided connection graph has 3 stages as shown in Fig. 8b).

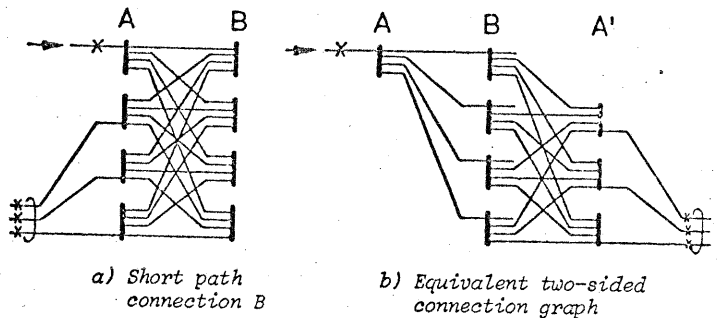

Fig. 8: Mapping of a one-sided (2-stage) connection graph into a two-sided (3-stage) one

Using the calculation method CLIGS (/1,2/) for the point-to-group loss we determine the effective accessibility  $k_{effB}$  from the calling inlet in stage A to those trunks of the desired outgoing group r being located within the same AB link block (cf. Fig. 8b)). Therewith we obtain the connection probability  $P_B$

$$P_B = E(k_{Ar}, n_r) - E(k_{Ar} + k_{effB}, n_r) \quad (24)$$

The first term of this equation means that an unsuccessful attempt has already been made to establish a connection via a short path A. The second term stands for the probability of loss via short path A and B. Hence it has to be subtracted to achieve the connection probability  $P_B$ .

Now, the carried traffic between stage B and C as well as behind the last stage C can be determined (cf. Equ. (2b), (2c)).

$$Y_{B,C} = Y - Y \cdot \frac{1 - E(k_{Ar}, n_r)}{1 - B_{PG}} - Y \cdot \frac{E(k_{Ar}, n_r) - E(k_{Ar} + k_{effB}, n_r)}{1 - B_{PG}} \cdot \frac{1}{2} \quad (25)$$

$$Y_{CC} = Y - Y \cdot \frac{1 - E(k_{Ar}, n_r)}{1 - B_{PG}} - Y \cdot \frac{E(k_{Ar}, n_r) - E(k_{Ar} + k_{effB}, n_r)}{1 - B_{PG}} \quad (26)$$

#### 4.4 Connection Probability $P_C$ for Short Path Connections C

The mapping procedure of the original one-sided connection graph leads to a 5-stage two-sided link system for the short path connection C. Again we determine the effective accessibility  $k_{effC}$  by the method CLIGS and get the connection probability  $P_C$

$$P_C = E(k_{Ar} + k_{effB}, n_r) - E(k_{Ar} + k_{effB} + k_{effC}, n_r) \quad (27)$$

#### 4.5 Connection Probability $P_N$ for Normal Connections

According to the method CLIGS, the effective accessibility  $k_{effN}$  is determined for the normal connections.

Hereby a 6-stage two-sided connection graph results from the mapping procedure. The connection probability  $P_N$  then becomes

$$P_N = E(k_{Ar} + k_{effB} + k_{effC}, n_r) - E(k_{Ar} + k_{effB} + k_{effC} + k_{effN}, n_r) \quad (28)$$

#### 4.6 Point-to-Group Loss $B_{PG}$

A call suffers a point-to-group loss, if no connection can be set up via short paths A, B and C as well as via normal path.

Inserting Equations (22), (24), (27) and (28) in Equation (4) leads to the resulting point-to-group loss  $B_{PG}$

$$B_{PG} = 1 - (P_A + P_B + P_C + P_N) \quad (29)$$

$$= E(k_{Ar} + k_{effB} + k_{effC} + k_{effN}, n_r)$$

## 5 GENERALIZATION OF THE CALCULATION METHOD

### 5.1 Systems with Concentration

The preceding two chapters only dealt with one-sided systems without concentration in any stage. Now, we also consider multiples with concentration ( $i > k$ ) in one or more stages. Then a situation may arise, where for a short path connection no idle outlet in the reversal multiple exists.

In a 3-stage one-sided link system we distinguish 3 different intermediate blocking probabilities:

- $B_{IA}$  - probability that all  $k_A$  outlets of the multiple in stage A (starting multiple) where the calling inlet is connected to, are busy. In this case no connection is possible at all.
- $B_{IB}$  - probability that all outlets of the multiples in stage B being accessible from the starting multiple are busy. In this case a call suffers a loss, if it has not yet found a short path connection A.
- $B_{IC}$  - probability that all outlets of the multiples in stage C being accessible from the starting multiple are busy. Here a call suffers a loss if it has not yet found a short path connection A or B.

The values of these blocking probabilities can be determined with the method CLIGS /1,2 /.

The connection probabilities  $P_{IA}$ ,  $P_{IB}$ ,  $P_{IC}$ ,  $P_{IN}$  in systems with intermediate blocking then are determined as follows:

$$\begin{aligned} P_{IA} &= (1 - B_{IA}) \cdot P_A \\ P_{IB} &= (1 - B_{IA}) \cdot (1 - B_{IB}) \cdot P_B \\ P_{IC} &= (1 - B_{IA}) \cdot (1 - B_{IB}) \cdot (1 - B_{IC}) \cdot P_C \\ P_{IN} &= (1 - B_{IA}) \cdot (1 - B_{IB}) \cdot (1 - B_{IC}) \cdot P_N \end{aligned} \quad (30)$$

In the case of point-to-point selection mode the connection probabilities  $P_A$ ,  $P_B$ ,  $P_C$  and  $P_N$  are calculated as indicated in Equ. (14), (16), (19) and (20). If point-to-group selection mode is applied Equ. (22), (24), (27) and (28) are taken as a basis.

### 5.2 Systems with Different Sizes of Trunk Groups and Different Carried Traffics

Up to now only the unrealistic case has been considered with groups of uniform size and equal carried traffic, in order to simplify the description of the calculation.

In this paragraph the extension to trunk groups with different sizes and different traffics will be made. For this purpose we define two probabilities:

- $a_j$  - probability that an offered call originates in a trunk group j,
- $i, j, k$  - probability that a call originating in group j wishes a connection to trunk group k.

For the calculation the values of  $Y_{j,k}$  - carried traffic caused by connections originating in trunk group j and terminating in trunk group k are prescribed for all combinations of j and k.

The traffic  $Y_{oj}$  comprises all connections originating in group j. The traffic  $Y_{Tj}$  are those connections terminating in group j.

These values are determined as follows:

$$Y_{oj} = \sum_{r=1}^R Y_{j,r} \quad j=1, \dots, R \quad (31)$$

$$Y_{Tj} = \sum_{r=1}^R Y_{r,j} \quad j=1, \dots, R \quad (32)$$

where R denotes the total number of trunk groups connected to the system.

The carried traffic per group then becomes

$$Y_j = Y_{oj} + Y_{Tj} \quad j=1, \dots, R \quad (33)$$

And finally the total carried traffic of the system reads

$$Y = \sum_{r=1}^R Y_r \quad (34)$$

If  $A_{oj}$  denotes the offered originating traffic from group j, the probability  $a_j$  is determined as follows

$$a_j = \frac{A_{oj}}{\sum_{r=1}^R A_{or}} \quad j=1, \dots, R \quad (35)$$

In our calculation methods we always start with the prescribed carried traffic and not with the offered traffic.

With the well known equation

$$Y = A(1 - B) \quad (36)$$

we obtain

$$a_j = \frac{Y_{oj}}{1-p(n_j)} \cdot \frac{1}{\sum_{r=1}^R \frac{Y_{or}}{1-p(n_r)}} \quad j=1, \dots, R \quad (37)$$

Hereby  $p(n_j)$  is determined according to Equ. (8) for a prescribed carried traffic  $Y_j$  of the considered trunk group.

Analogously we calculate the probabilities  $i_{j,k}$

$$i_{j,k} = \frac{Y_{j,k}}{1-p(n_k)} \cdot \frac{1}{\sum_{r=1}^R \frac{Y_{j,r}}{1-p(n_r)}} \quad j,k=1, \dots, R \quad (38)$$

The connection probabilities then become in the case of point-to-point selection mode

$$\begin{aligned} P_A &= \sum_{\xi=1}^R a_{\xi} \sum_{\eta=1}^R i_{\xi,\eta} \cdot W_{A,\eta} \\ P_B &= \sum_{\xi=1}^R a_{\xi} \sum_{\eta=1}^R i_{\xi,\eta} \cdot W_{B,\eta} \cdot (1-B_B) \\ P_C &= \sum_{\xi=1}^R a_{\xi} \sum_{\eta=1}^R i_{\xi,\eta} \cdot W_{C,\eta} \cdot (1-B_C) \\ P_N &= \sum_{\xi=1}^R a_{\xi} \sum_{\eta=1}^R i_{\xi,\eta} \cdot W_{N,\eta} \cdot (1-B_N) \end{aligned} \quad (39)$$

In order to calculate the partial losses  $B_B$ ,  $B_C$  and  $B_N$  we proceed in the same way as outlined in Chapter 3. This is due to the fact that the point-to-point loss is independent of the group size and its carried traffic (cf. /3/).

If marking strategy b) is applied, the probabilities  $W_{A,\eta}$ ,  $W_{B,\eta}$ ,  $W_{C,\eta}$  and  $W_{N,\eta}$  ( $\eta=1, \dots, R$ ) are calculated depending on the size and the carried traffic of trunk group  $\eta$  (cf. Equ. (7)). They are independent of the size and traffic in case of marking strategy a) (cf. Equ. (6)).

We obtain the connection probabilities in case of point-to-group selection by replacing the terms  $W_{j,\eta} \cdot (1-B_j)$  in Equations (39) with Equations (22), (24), (27) and (28).

## COMPARISON OF SIMULATION AND CALCULATION

### 6.1 Remarks on Simulation

In order to check the reliability of the calculation method a simulation program using the Monte Carlo method has been written. Numerous simulation runs have been performed with different link system structures. Path hunting within the system always starts from a home position. For each group Pure Chance Traffic of Type 1 (PCT1) has been realized. The simulation results in the following diagrams are plotted with their 95 % confidence intervals. For one loss value at least 100,000 test calls have been performed.

### 6.2 Systems without Concentration

Fig. 9 shows simulation and calculation results for a 3-stage one-sided link system with  $N=750$  inlets/outlets. Here the point-to-group selection mode is applied and therefore the point-to-group loss  $B_{PG}$  is plotted versus the carried traffic per termination  $Y/N$ . The two bold lines are calculation results

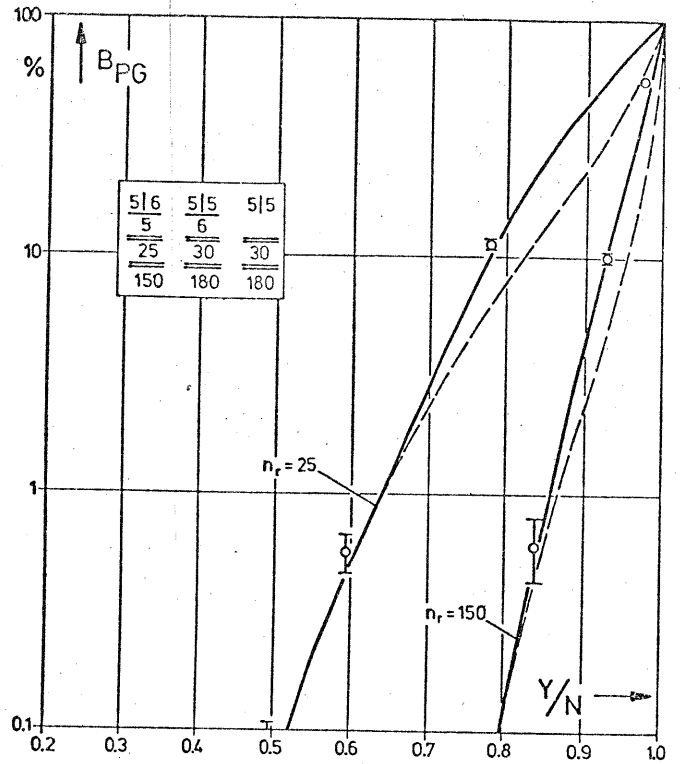

Fig. 9: Point-to-group loss  $B_{PG}$  of a 3-stage one-sided link system with short path connections

Simulation:

○

Calculation:

---

Fully accessible group: - - - -

obtained by the calculation method described in Chapter 4. In the upper curve 30 trunk groups with  $n_r=25$  each are connected to the system; and in the lower one we have 5 trunk groups with  $n_r=125$  each. For comparison the dashed lines denote the loss of a fully accessible group ( $n_r=25$  and  $n_r=150$ ).

In the next diagram (cf. Fig.10) the same one-sided link system is considered but now operating in the point-to-point selection mode. Here the point-to-point loss  $B_{PP}$  is plotted versus the carried traffic per termination  $Y/N$ . The uppermost curve denotes the loss probability if marking strategy a) is applied (cf. Chapter 3.1). In this case the size of the trunk groups connected to the system (here 5 groups of  $n_r=150$ ) does not influence the loss. The two other curves together with their simulation results are obtained when marking strategy b) is used. Here the loss probability increases as the trunk group size decreases. An explanation for this fact is that the possibility of switching a call via a short path diminishes as the size of the trunk groups decreases.

The last diagram Fig. 11 of this section shows the carried traffic per link between the different stages of the same 3-stage one-sided system. The calculation and simulation results for  $Y_{A,B}/N$ ,  $Y_{B,C}/N$  and  $Y_{C,C}/N$  are plotted versus the carried traffic  $Y/N$  on the 750 terminations on the left hand side of the system. In this example point-to-point selection mode with marking strategy b) (5 trunk groups with  $n_r=150$ ) has been applied. As outlined above this marking strategy and a large trunk group size yields the lowest loss. Furthermore, the traffic loads decrease rapidly between the last stages ( $Y_{B,C}$  and  $Y_{C,C}$ ) for a given  $Y/N$  as it can be seen in Fig.11.

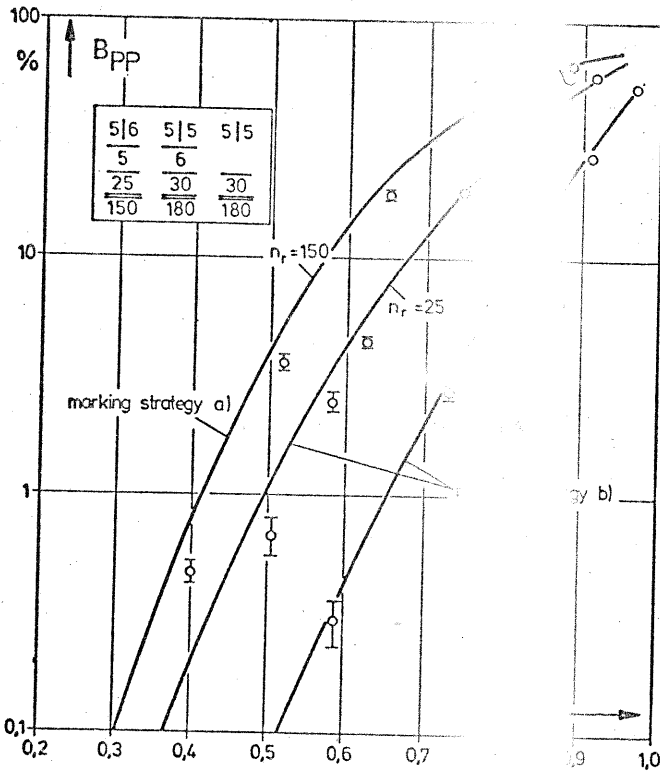

Fig. 10: Point-to-point loss of a 3-stage link system with short path connection  
Simulation:  $\square$   
Calculation: —

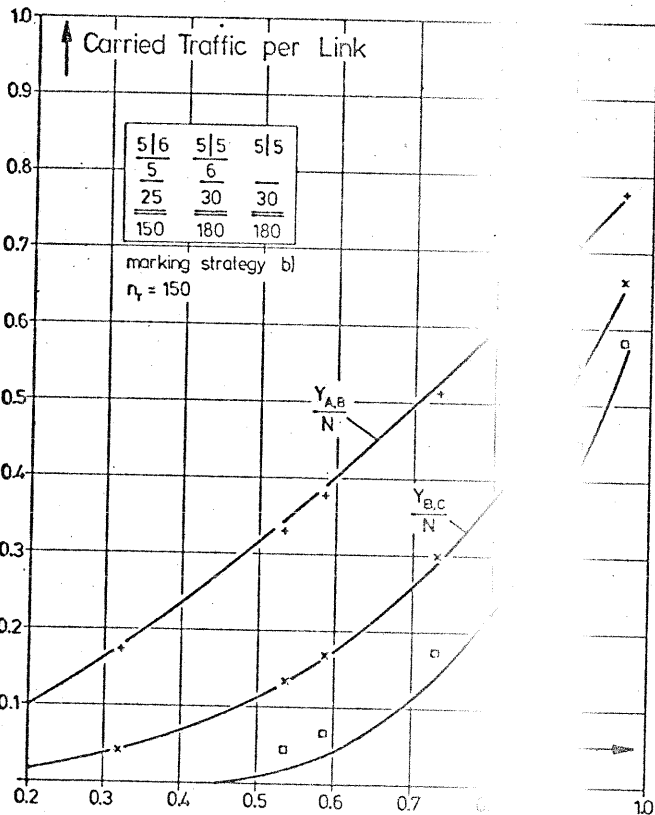

Fig. 11: Carried traffic per link in a 3-stage link system operating in the point-to-point selection mode  
Simulation: +, x,  $\square$   
Calculation: —

### 6.3 Systems with Concentration

In Fig. 12 again a 3-stage one-sided link system is shown. This system concentrates in the first stage (switches 10|5) as well as in the last stage (switches 5|2). The selection mode is point-to-point selection with marking strategy a) (upper curve) and marking strategy b) (lower curve). The simulation results are given with their confidence intervals.

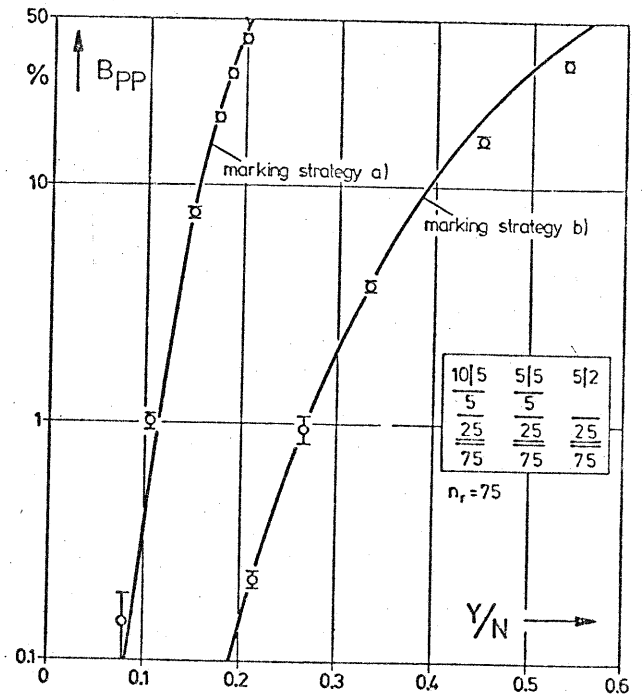

Fig. 12: Point-to-point loss  $B_{pp}$  of a 3-stage one-sided link system with concentration  
Simulation:  $\square$   
Calculation: —

#### ACKNOWLEDGMENT

The author wishes to thank Professor Dr.-Ing. A. Lotze and Dipl.-Ing. G. Thierer for many valuable discussions. Also the author is grateful to the Deutsche Forschungsgemeinschaft (DFG) for supporting this study for many years.

#### REFERENCES

- 1/ BAZLEN, D. On the Influence of Hunting Mode and Link Wiring on the Loss of Link Systems.  
a) Proceedings 7th ITC Stockholm 1973, pp 232/1-12.  
b) Information Express, Information Transmission, September 1973, Vol. 35, pp 11-39 (in Russian).
- 2/ BAZLEN, D. Design Parameters and Loss Calculation of Link Systems.  
KAMPE, G. LOTZE, A.: IEEE-Comm.22(1974)12, pp 1908-1920.
- 3/ LOTZE, A. PPL - A Reliable Method for the Calculation of Point-Point Loss in Link Systems.  
RÖDER, A. THIERER, G.:  
a) Proceedings 8th ITC Melbourne 1976, pp 547/1-14.  
b) Conference Record ICC 1977, Chicago, Vol 1, pp 213-226.
- 4/ LOTZE, A. Investigations on Folded and Reversed Link Systems.  
RÖDER, A. THIERER, G.:  
a) Proceedings 8th ITC Melbourne 1976, pp 544/1-5.  
b) Conference Record ICC 1977, Chicago, Vol 1, pp 232-236.
- 5/ LOTZE, A. On the Point-to-Point Loss in Link Systems with Symmetrical THIERER, G.: or Interleaved Link Wiring. (To be Published)