



Copyright Notice

© 2003 IEEE. Personal use of this material is permitted. However, permission to reprint/republish this material for advertising or promotional purposes or for creating new collective works for resale or redistribution to servers or lists, or to reuse any copyrighted component of this work in other works must be obtained from the IEEE.

This material is presented to ensure timely dissemination of scholarly and technical work. Copyright and all rights therein are retained by authors or by other copyright holders. All persons copying this information are expected to adhere to the terms and constraints invoked by each author's copyright. In most cases, these works may not be reposted without the explicit permission of the copyright holder.

Totally Blind APP Channel Estimation for Mobile OFDM Systems

Frieder Sanzi and Marc C. Necker

Abstract—A new two-dimensional blind channel estimation scheme for coherent detection of OFDM signals in a mobile environment is presented. The channel estimation is based on the A Posteriori Probability (APP) calculation algorithm. The time-variant channel transfer function is completely recovered without phase ambiguity with no need for *any* pilot or reference symbols, thus maximizing the spectral efficiency of the underlying OFDM system. The phase ambiguity problem is solved by using a 4-QAM scheme with asymmetrical arrangement. The results clearly indicate that totally blind channel estimation is possible for virtually any realistic time-variant mobile channel.

Index Terms—OFDM, blind channel estimation, iterative decoding

I. INTRODUCTION

In mobile communication systems, channel estimation (CE) is an important issue, since the receiver needs to have knowledge of the time-varying channel transfer function (CTF) in order to perform coherent detection. A common way to support channel estimation is to periodically insert pilot symbols into the transmitted data stream and use FIR interpolation filters, as described in [1], for example.

Another method to estimate the channel is based on the calculation of the A Posteriori Probability (APP), as described in [2]. The estimation of the two-dimensional CTF is performed by a concatenation of two one-dimensional APP estimators in frequency and time direction, respectively. This method enables a dramatical reduction of the amount of pilot symbols compared to the FIR interpolation method. Furthermore, the APP channel estimation stage can be embedded into an iterative decoding loop with a soft in/soft out decoder.

Since pilot symbols reduce the spectral efficiency, a lot of work has been done in the area of blind channel estimation, which makes pilot symbols unnecessary. Most research has focused on methods based on higher order statistics, which converge slowly, making them unsuitable for mobile environments. Moreover, a phase ambiguity is introduced in the channel estimate, which makes at least one reference symbol necessary to resolve. In [3] the authors present a fast converging blind channel estimator for OFDM-systems based on the Maximum Likelihood principle, which recovers the channel's amplitude and phase without the need for any reference symbols. This is achieved by combining two modulation schemes, such as QPSK and 3-PSK.

F. Sanzi is with the Institute of Telecommunications, Dep. 051100, University of Stuttgart, Pfaffenwaldring 47, 70569 Stuttgart, Germany. Tel: +49 711 685 7941, Fax: +49 711 685 7929 (E-mail: sanzi@inue.uni-stuttgart.de).

M. C. Necker is with the Institute of Communication Networks and Computer Engineering, University of Stuttgart, Pfaffenwaldring 47, 70569 Stuttgart, Germany. Tel: +49 711 685 7963, Fax: +49 711 685 7983 (E-mail: necker@ikr.uni-stuttgart.de).

In this paper we combine the idea of totally blind and APP channel estimation (APP-CE). We use a modulation scheme with an asymmetrical arrangement to solve the phase ambiguity problem. An iterative loop consisting of the blind APP-CE and an APP decoder is applied at the receiver to further reduce the BER [2]. Our approach is not limited to two-dimensional channel estimation and can also be applied to higher order modulation schemes. In addition to the BER-performance, the iterative decoding loop is studied with the Extrinsic Information Transfer chart (EXIT chart) [4].

II. SYSTEM MODEL

The block diagram of the transmitter is given in Fig. 1. The sequence b_ν from the binary source is encoded by a convolutional encoder. Its output signal consists of the coded bits c_μ , which is fed into the interleaver with output signal \tilde{c}_μ . After interleaving, two successive coded bits are grouped and mapped onto a 4-QAM symbol $X_{k,l}$ with asymmetrical arrangement as shown in Fig. 2.

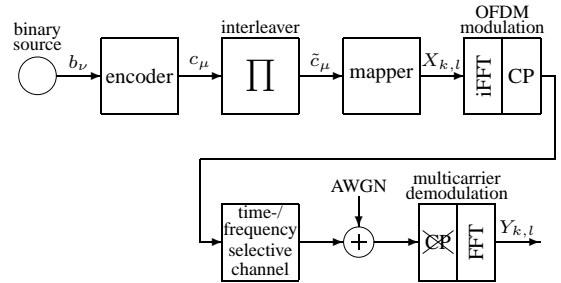

Fig. 1. Transmitter and channel model.

The signal $X_{k,l}$ is modulated onto K orthogonal sub-carriers by an iFFT-block. The transmission is done on a block-by-block basis, with blocks of K sub-carriers in frequency and L OFDM symbols in time direction. After iFFT, the cyclic prefix (CP) of length 1/4 is inserted and the output is fed into the channel.

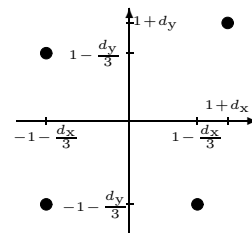

Fig. 2. 4-QAM constellation diagram with asymmetrical arrangement.

For the mobile channel we use the wide-sense stationary uncorrelated scattering (WSSUS) channel model introduced

in [5]. The time varying CTF can be expressed as:

$$H(f, t) = \frac{1}{\sqrt{M}} \sum_{i=1}^M e^{j(\varphi_i + 2\pi f_{D_i} t - 2\pi f \tau_i)} . \quad (1)$$

The variable M denotes the number of propagation paths; the phase φ_i is uniformly distributed, the delay spread τ_i exponentially distributed with probability density function (PDF) $p_\tau(\tau)$. The Doppler-shift f_{D_i} is distributed according to Jakes' power spectral density. The auto-correlation function in time is $R_{t;l} = J_0(2\pi f_{D_{\max}} \cdot l \cdot T_s)$, where T_s is the duration of one OFDM symbol (useful part plus CP), l the discrete time index and $f_{D_{\max}}$ the maximal Doppler shift. The complex auto-correlation function in frequency direction can be calculated as (see [6])

$$R_{f;k} = \frac{1 - e^{-\tau_{\max}(\frac{1}{\tau_{\text{rms}}} + j2\pi \cdot k \cdot \Delta f)}}{(1 - e^{-\frac{\tau_{\max}}{\tau_{\text{rms}}}}) \cdot (1 + j2\pi \cdot k \cdot \Delta f \cdot \tau_{\text{rms}})}, \quad (2)$$

where Δf is the sub-carrier spacing and k is the discrete frequency index. τ_{rms} is chosen such that $p_\tau(\tau_{\max})/p_\tau(0) = 1/1000$ with τ_{\max} being the maximal delay spread.

At the receiver, we obtain the received 4-QAM constellation points $Y_{k,l}$ after removal of the cyclic prefix and OFDM demodulation with FFT:

$$Y_{k,l} = H_{k,l} \cdot X_{k,l} + N_{k,l} , \quad (3)$$

whereby $N_{k,l}$ are statistically i. i. d. complex Gaussian noise variables with component-wise noise power $\sigma_N^2 = N_0/2$. The $H_{k,l}$ are sample values of the CTF.

The signal $Y_{k,l}$ is fed to the two-dimensional blind APP-CE stage as shown in Fig. 3. This stage outputs log-likelihood ratios $L_{d,\mu}^{\tilde{c}}$ on the transmitted coded bits which are deinterleaved and decoded in an APP decoder. Iterative channel estimation and decoding is performed by feeding back extrinsic information on the coded bits; after interleaving it becomes the *a priori* knowledge $L_{a,\mu}^{\tilde{c}}$ to the blind APP-CE stage.

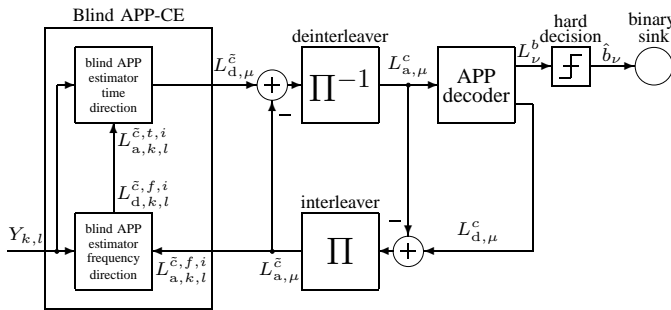

Fig. 3. Receiver with iterative blind APP channel estimation.

III. APP CHANNEL ESTIMATION

A. One-dimensional APP Channel Estimation

The two-dimensional blind APP channel estimator consists of two estimators for frequency and time direction, respectively [2]. This estimation algorithm exploits the time and frequency continuity of the CTF at the receiver.

For one-dimensional APP estimation, the symbol-by-symbol MAP-algorithm is applied to an appropriately chosen metric. To help understanding, the symbols $X_{k,l}$ at the transmitter in Fig. 1 can be thought of being put into a virtual shift register at the output of the mapper. Owing to this “artificial grouping” the corresponding trellis exploits the time and frequency continuity of the CTF at the receiver.

At frequency index k , the APP estimation in frequency direction is characterized for OFDM symbol l_0 with $0 \leq l_0 \leq L - 1$ by the metric increment

$$\gamma_k = -\frac{|Y_{k,l_0} - \hat{H}_{k,l_0}^f \cdot \hat{X}_{k,l_0}|^2}{2 \cdot \sigma_f^2} + \sum_{i=0}^1 d_{k,l_0}^i \cdot L_{a,k,l_0}^{\tilde{c},f,i} \quad (4)$$

with estimated channel coefficient

$$\hat{H}_{k,l_0}^f = \sum_{i=1}^{m_f} u_{f,i} \cdot \frac{Y_{k-i,l_0}}{\hat{X}_{k-i,l_0}}, \quad (5)$$

whereby the FIR filter coefficients $u_{f,i}$ are calculated with the Wiener-Hopf equation based on the frequency auto-correlation function $R_{f;k}$ [2]. m_f is the prediction order. The \hat{X}_{k,l_0} denote the hypothesized transmitted data symbol according to the trellis structure and the $L_{a,k,l_0}^{\tilde{c},f,i}$ are the *a priori* L-values of the coded bits \tilde{c}_μ which are fed to the APP estimator in frequency direction. The bits d_{k,l_0}^0 and d_{k,l_0}^1 in the sum in (4) result from the hard demapping of \hat{X}_{k,l_0} . The term $2\sigma_f^2$ is the variance of the estimation error in frequency direction according to [7]. The APP estimation in time direction is done in a similar way for each sub-carrier taking the time auto-correlation function of the CTF $R_{t;l}$ into account [2]. The two one-dimensional APP estimators are concatenated as shown in Fig. 3. The output $L_{d,k,l}^{\tilde{c},f,i}$ of the APP estimator in frequency direction becomes the *a priori* input $L_{a,k,l}^{\tilde{c},t,i}$ of the APP estimator in time direction. The prediction order for estimation in frequency and time direction, respectively, is set to two in the following.

B. Totally Blind APP Channel Estimation

The concept of totally blind channel estimation was first introduced in [3]. It is founded on the idea of exploiting the correlation of the CTF in frequency direction and using two different PSK-modulation schemes on adjacent subcarriers to resolve the phase ambiguity. If the CTF does not vary fast in frequency direction, the receiver can determine symbols sent on adjacent subcarriers without any ambiguity by solving the following equation system for adjacent subcarriers ($H_{k,l} \approx H_{k+1,l}$, $N_{k,l} = 0$):

$$Y_{k,l} = H_{k,l} \cdot X_{k,l} , \quad (6)$$

$$Y_{k+1,l} = H_{k,l} \cdot X_{k+1,l} . \quad (7)$$

If only QPSK is used, $X_{k,l} = e^{j\frac{\nu}{2}} X_{k+1,l}$ has to be chosen, introducing the well known phase ambiguity. This can be resolved by using two different PSK-modulation schemes on adjacent subcarriers. Let $X_{k,l}$ be a signal point of the first PSK-modulation scheme and $X_{k+1,l}$ a signal point of the second modulation scheme. If $\alpha = \angle(X_{k,l}, X_{k+1,l})$ denotes the angle between both signal points in the complex plane, the signal points must be chosen such that no two angles α

are identical for all possible signal point combinations. For example, QPSK and 3-PSK fulfil this condition. In this case, the equation system (6) and (7) can be solved without any phase ambiguity, since $\tilde{\nu}$ can no longer be chosen arbitrarily. In the noisy case, an ML-approach has to be used [3]. Simulations showed good BER-performance with COST207-channels RA and TU. For channels with longer delay spreads, this concept imposes problems as the condition of a slow varying CTF in frequency direction only holds for some subcarriers.

The APP channel estimator calculates the most likely transmitted symbol sequence $\hat{X}_{k,l}$ conditioned on the received symbol sequence $Y_{k,l}$ in consideration of the time and frequency continuity of the CTF. Using symmetrical constellations diagrams the transmission of pilot symbols is mandatory necessary [2], as any symbol sequence $e^{j\tilde{\varphi}}\hat{X}_{k,l}$ is a possible solution for the APP-CE. Extending the concept of totally blind channel estimation to APP-CE, we can use a modulation scheme with an asymmetrical constellation diagram, e. g. as shown in Fig 2, to solve the phase ambiguity. Again, this is possible because $\tilde{\varphi}$ can no longer be chosen arbitrarily.

IV. SIMULATION RESULTS

We use a sub-carrier spacing of $\Delta f = 4\text{kHz}$ and an OFDM-symbol duration of $T_s = 312.5\mu\text{s}$. The cyclic prefix of length $T_g = 62.5\mu\text{s}$ adds redundancy, corresponding to an information rate R_g of

$$R_g = \frac{T_s - T_g}{T_s} = 0.8. \quad (8)$$

For the block-wise transmission we use $K = 1001$ adjacent sub-carriers and $L = 101$ consecutive OFDM symbols. $d_x = d_y = 0.25$ was chosen for the 4-QAM modulation according to Fig 2, and Gray mapping with two bits per symbol was used. Hence, the interleaving depth is $V_L = 2 \cdot K \cdot L = 202202$.

As an example, the used convolutional code is recursive systematic with feedback polynomial $G_r = 037_8$, feed-forward polynomial $G = 023_8$, memory 4 and code rate $R_c = 0.5$. Note, that in the following all E_b/N_0 -values are given with respect to the overall information rate

$$R = R_c \cdot R_g = 0.4. \quad (9)$$

The simulations were done with different maximal Doppler shifts $f_{D\max}$ and different maximal delay spreads τ_{\max} . As performance measure, the bit error ratio (BER) at the output of the hard decision device of the receiver in Fig. 3 is used. Furthermore, we apply the Extrinsic Information Transfer (EXIT) chart [4] to gain insight into the convergence behaviour of the iterative decoding loop.

Fig. 4 shows the EXIT charts for different channel parameters and $E_b/N_0 = 8\text{dB}$. The trajectories show the exchange of information between the blind APP-CE stage and the APP decoder. For $f_{D\max} = 100\text{Hz}$, the trajectory ends at the intersection of the characteristic curves after one iteration. For $f_{D\max} = 300\text{Hz}$ the characteristic curve of the blind APP CE stage starts at a lower mutual information I_{E1} , resulting in a higher iterative decoding gain. Hence, two iterations are necessary for optimal performance.

In Fig. 5 the BER is shown for the proposed system. As can

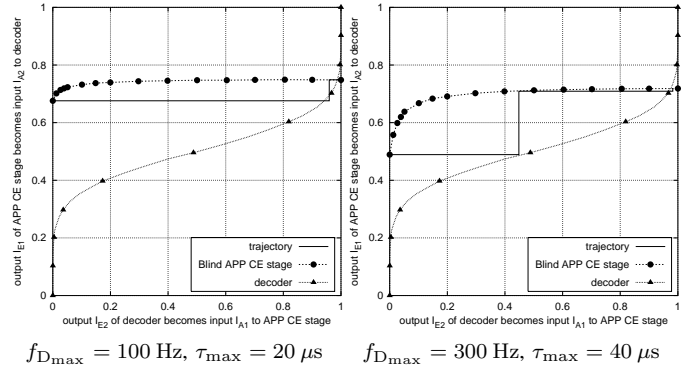

Fig. 4. EXIT charts, blind APP-CE stage and decoder with simulated trajectory of the iterative decoding loop at $E_b/N_0 = 8\text{dB}$

be seen, totally blind CE with coherent demodulation delivers excellent BER-performance after very few iterations.

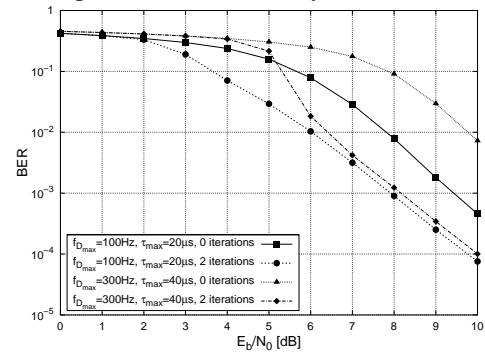

Fig. 5. BER for iterative blind APP-CE after 0 and 2 iterations

V. CONCLUSION

The concept of totally blind channel estimation was successfully applied to two-dimensional APP channel estimation. The result is a true blind channel estimator, which is capable of estimating the time-variant channel transfer function including its absolute phase. This is achieved without the need for any reference symbols, thus maximizing the spectral efficiency of the underlying OFDM system. Our results clearly indicate that totally blind channel estimation is possible for virtually any realistic time-variant mobile channel.

REFERENCES

- [1] P. Höher, S. Kaiser, and P. Robertson, "Two-dimensional pilot-symbol-aided channel estimation by Wiener filtering", *Proc. ICASSP, Munich*, pp. 1845–1848, Apr. 1997
- [2] F. Sanzi and S. ten Brink, "Iterative channel estimation and decoding with product codes in multicarrier systems", *Proc. IEEE Vehicular Technology Conf. (VTC), Boston*, pp. 1338–1344, Sep. 2000
- [3] M. C. Necker and G. L. Stüber, "Totally blind channel estimation for OFDM over fast varying mobile channels", *Proc. IEEE Intern. conf. on Comm. (ICC), New York*, pp. 421–425, Apr. 2002
- [4] S. ten Brink, "Convergence behavior of iteratively decoded parallel concatenated codes", *IEEE Trans. Comm.*, vol. 49, no. 10, pp. 1727–1737, Oct. 2001
- [5] P. Höher, "A statistical discrete-time model for the WSSUS multipath channel", *IEEE Trans. on Veh. Tech.*, vol 41, pp. 461–468, Nov. 1992
- [6] O. Edfors, M. Sandell, J.-J. van de Beek, S. K. Wilson, and P. O. Börjesson, "OFDM channel estimation by singular value decomposition", *IEEE Trans. Comm.*, vol. 46, no. 7, pp. 931–939, July 1998
- [7] P. Höher and J. Lodge, "Iterative decoding/demodulation of coded DPSK systems", *Proc. IEEE Global Telecommun. Conf. (Globecom), Sydney, Australia*, pp. 598–603, Nov. 1998