

Investigations on Folded and Reversed Link Systems

Alfred Lotze, Alexander Röder and Gebhard Thierer
University of Stuttgart, Stuttgart, Federal Republic of Germany

ABSTRACT

This paper is the second of a 3-paper study presented at the 8th ITC. The first paper deals with the point-to-point loss in two-sided link systems /1/. The third one gives a comparison between the point-to-point selection mode vs. the point-to-group selection mode /2/.

This paper here deals with one-sided link systems. These systems can be mapped into equivalent two-sided ones with respect to their traffic behavior. Thus, methods for the approximate calculation of loss in case of the point-to-point selection mode as well as for point-to-group selection mode can be applied. A good agreement between simulation and calculation is achieved in both cases.

1. INTRODUCTION

Two main types of link systems are known:

Two-Sided Link Systems

Link systems where incoming and outgoing groups are connected on both sides of the switching array (c.f. Fig.1). This does not imply that both way traffic is impossible.

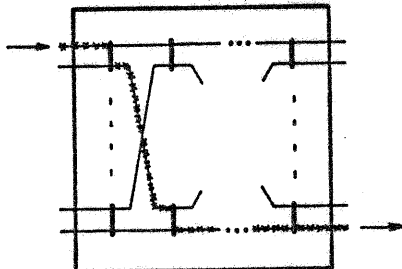

Fig.1: Two-sided link system

However, it is not possible to establish a connection between two terminations located on the same side of the array. This can be achieved by so-called One-Sided Link Systems.

One-Sided Link Systems

Link Systems where all trunk groups are connected to one side of the switching array. The outlets on the other side may be wired in two different ways:

- Folded Systems

Each outlet on the right hand side is connected to the likewise numbered inlet on the left hand

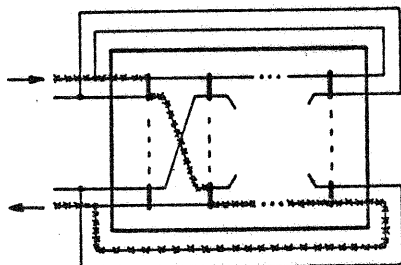

Fig.2: Folded System

side. A connection through this system requires only one path through the system (Fig.2).

- Reversed System

All outlets on the right hand side are looped among themselves. A connection through this system requires two paths (one loop) through the system.

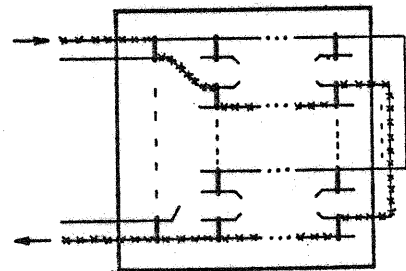

Fig.3: Reversed System

The aim of this paper is to present good approximate methods for the loss calculation for one-sided link systems operating in the point-to-point selection mode (PPS) or in the point-to-group selection mode (PGS). For this purpose, one-sided systems are mapped into two-sided ones.

Thus, known approximate formulae may be applied for the calculation of loss, both for the PGS-mode /3,4/ and PPS-mode /1/ (see Fig.4). Also optimization methods known from two-sided link systems, e.g. minimization of crosspoint requirements /1,9/ may be applied.

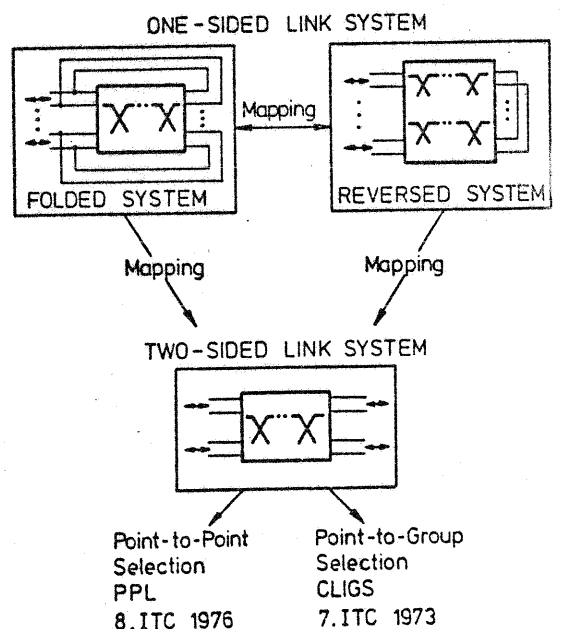

Fig.4: Flow chart showing the procedure of mapping and loss calculations of one-sided link systems

2. MAPPING METHODS

In the first part of this chapter, it will be shown how to map one-sided link systems, i.e. a reversed one into a folded one and vice versa (upper part of Fig.4).

The second part deals with the mapping procedure of one-sided link systems into two-sided ones.

2.1 Mutual Mapping of One-Sided Link Systems

2.1.1 Mapping of Folded Systems into Reversed Ones

- Systems with an even number of stages

As an example, Fig. 5 shows how to map a small 4-stage folded system into a reversed one.

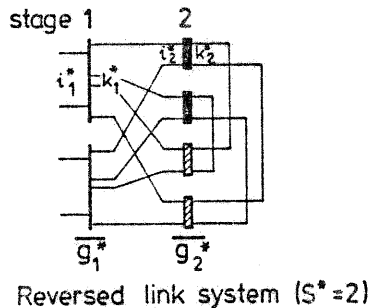
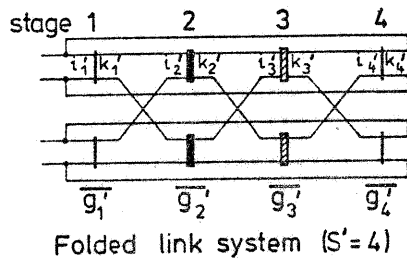

Fig.5: Mapping of a folded link system with an even number of stages into a reversed one

From Fig.5 the following mapping equations can be derived. The notations used for the reversed system, are marked with an asterisk (*), and those for the original folded system with a prime (').

$$\begin{aligned} \text{number of stages} & S^* = S'/2 \quad (S'=4,6,\dots) \\ \text{number of multiples in stage 1:} & g_1^* = g_1' \quad (=g_{S'}') \\ \text{number of multiples in stage } j: & g_j^* = 2g_j' \quad (2 \leq j \leq S^*) \\ \text{inlets per multiple in stage } j: & i_j^* = i_j' \quad (1 \leq j \leq S^*) \\ \text{outlets p. multiple in stage 1:} & k_1^* = 2k_1' \\ \text{outlets p. multiple in stage } j: & k_j^* = k_j' \quad (2 \leq j \leq S^*) \end{aligned}$$

The outlets of the last stage (on the right hand side) in the reversed system are wired as shown in Fig.5. It should be pointed out that also the amount of crosspoints required is the same in the folded system as well as in the reversed system.

- Systems with an odd number of stages.

For folded systems having an odd number of stages, a fictitious stage has to be added for the mapping procedure in order to get an even number of stages. Parallel wiring of the links between this extra stage and the original middle stage is required hereby. Thus, no change in the traffic behavior of the folded system is guaranteed. As an example, Fig.6 shows a small 3-stage folded link system with its added extra stage. This pseudo 4-stage system may now be transformed by applying the procedure as previously described. However, this equivalent reversed system now requires more crosspoints than the original folded one, because of the added extra stage.

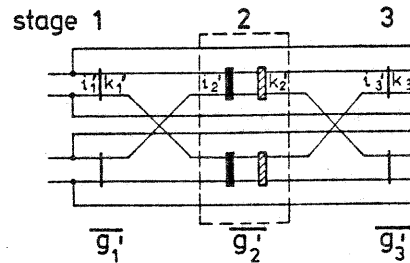

Folded link system ($S'=3(4)$)

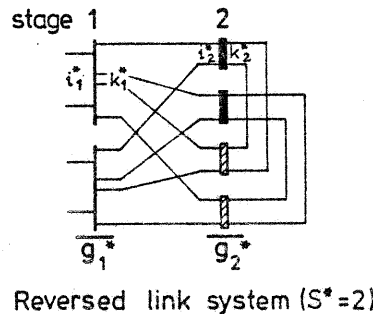

Fig.6: Mapping of a folded link system with an odd number of stages into a reversed one

Analogously, the mapping equations are the same except the one for the number of stages which reads:

number of stages: $S^* = (S'+1)/2$ ($S'=3,5,\dots$)
The outlets of the last stage of the reversed system are wired as shown in Fig.6.

As it can be seen from Fig.5 and 6, 3-stage as well as 4-stage folded systems lead to 2-stage reversed systems which differ in the wiring of the outlets of the last stage only. In practice, a reversed system with wiring as shown in Fig.6 is obviously not to recommend.

2.1.2 Mapping of Reversed Systems into Folded Systems

Whereas any symmetrical folded system can be mapped into a reversed system, there exist certain constraints for mapping a reversed system into a folded one. These constraints are:

The outlets of the last stage have to be wired in such a manner, that the outlets of exactly one half of the number of the multiples in the last stage are connected only to those of the other half. In other words, two classes of multiples must be found whose outlets must not be wired among themselves, but only to those multiples of the opposite class. Then, the mapping equations can be used analogously.

Thus, after mapping, one class of multiples becomes stage 2 and the other one becomes stage 3 in a folded system (cf. again Fig.5).

The following conclusions can be drawn: Obviously, an exact mapping of a reversed system into a folded system requires certain symmetry conditions. Then from its fully equivalent wiring and hunting scheme, one can conclude a fully identical loss vs. load behavior. This has also been certified by simulations.

2.2 Mapping of One-Sided Link Systems into Two-Sided Link Systems

Whereas the mutual mapping of folded and reversed systems yields an identical traffic behavior, the mapping of one-sided systems into two-sided ones yields only a very close approximation. The reason will be explained later on.

This section describes the mapping of one-sided link systems into two-sided ones. Only the mapping of folded systems into two-sided ones is regarded, since suitably wired reversed systems have absolutely identical folded systems as counterparts (cf. Chapter 2.1). Fig.7 shows a 4-stage folded link system and its corresponding two-sided link system. For reason of clarity, an example with specific values has been given.

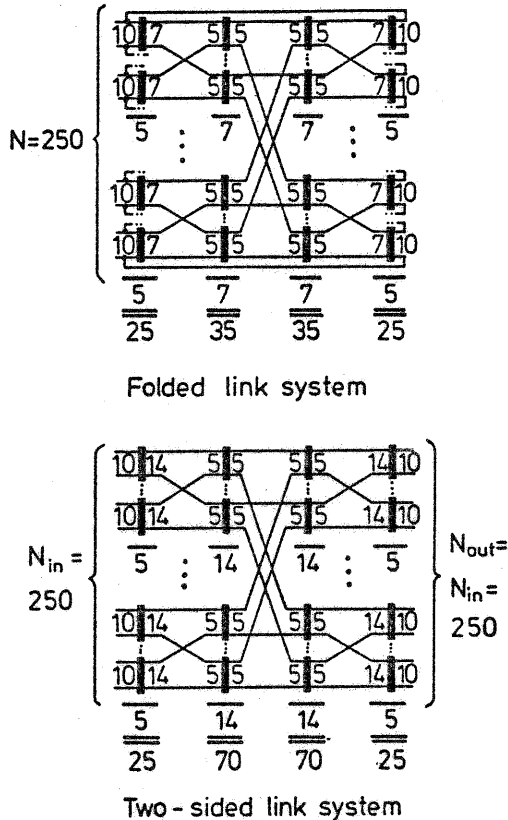

Fig.7: Mapping of a folded link system into a two-sided link system

As it can be seen, the basic idea is that the two-sided system has twice as much trunks as does the folded system which has to be mapped. In other words, the one-sided (folded) system has a total of N terminations all being on one side. The two-sided system, however, has N inlets or outlets, respectively, on each side of the system. Thus, the two-sided system can handle twice the traffic. The hereby occurring probability of loss corresponds to that one of the one-sided system.

In the following mapping equations, the variables marked with a prime (') denote the one-sided (folded) system, the variables for the two-sided system are unmarked.

- number of stages: $S=S'$
- number of multiples in stage 1, S: $g_1=g_s=g'_1=g'_s$
- number of multiples in stage j: $g_j=2 \cdot g'_j$ ($2 \leq j \leq S-1$)
- inlets per multiple in stage j: $i_j=i'_j$ ($1 \leq j \leq S-1$)
- inlets per multiple in stage S: $i_s=2 \cdot i'_s$
- outlets per multiple in stage 1: $k_1=2 \cdot k'_1$
- outlets per multiple in stage j: $k_j=k'_j$ ($2 \leq j \leq S$)

It can be verified that the mapping of Fig.7 fulfills these above mapping equations.

3. FURTHER REMARKS ON FOLDED SYSTEMS

As shown in Fig.8, in a folded system there are always two possibilities to find a set of paths for a connection between two certain trunks.

The first set of paths leads from the calling trunk A on the left hand side through the system along the dashed line in Fig.8. It leaves the system via the trunk B on the right hand side. This trunk B is identical with the trunk B because of the external loop. A second set of paths starts via the external loop from a trunk A from the right hand side of the system to the termination trunk B. Thus, in the above example, there are $2 \cdot k'_1$ paths available for a connection between trunk A and trunk B. However, if the trunks A and B both are wired to the same link block, the $2 \cdot k'_1$ sets of paths leading from A to B have the links between the middle stages in common; this results in an increase of loss for that kind of connection.

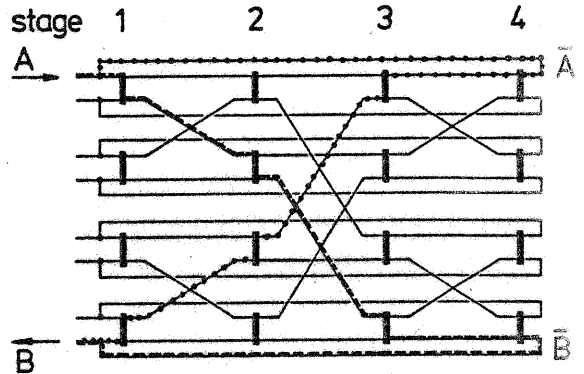

Fig.8: Possible sets of paths for a connection between two trunks

To overcome this bottle-neck, one has to provide an extra link between likewise numbered multiples in stage 2 and 3 (see Fig.9). This guarantees that switching between trunks connected to the same link block can be done via the same number of paths through the system as otherwise. The same consideration holds for reversed systems, too.

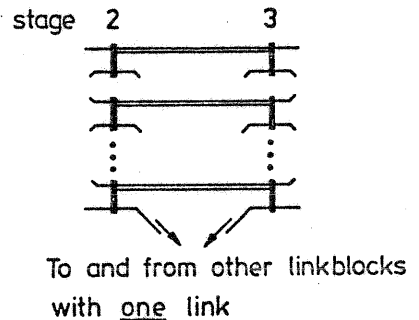

Fig.9: Sketch of folded systems with extra double linkage between likewise numbered multiples

It should be noted that this double linkage between likewise numbered multiples in stage 2 and 3 has to be disregarded for the mapping according to Chapter 2.2, because in a two-sided substitute system this above mentioned bottleneck does not occur. Hence, in order to achieve the same grade of service in a folded system as in a corresponding two-sided one, some extra crosspoints have to be spent.

The only bottle-neck in a folded system which cannot be avoided occurs if a calling trunk A has to be switched to a trunk B of the desired group which is connected to the same multiple. In that case, there exists only one set of paths (consisting of k_1) through which a connection is possible. By a suitable strategy of the marker, this case will be very seldom.

Up to now, only point-to-point selection (definition see Chapter 4.2) has been regarded. In the case of point-to-group selection (definition see Chapter 4.3) the influence of the above mentioned bottleneck is negligible in any case.

Another loss increasing effect occurs, if a connection has to be made between two trunks of the same group via the link system. This so-called "Internal Traffic" increases the loss of the considered group. However, it does not influence the grade of service of the system, unless the two trunks are wired to the same multiple (see above). The loss calculation in case of internal traffic has been published in /6/.

4. CALCULATION OF LOSS IN ONE-SIDED SYSTEMS

4.1 General Remarks

Due to the lack of space, only symmetrical 4-stage systems are regarded in the following. However, the method of mapping is also valid for symmetrical systems with a number of stages other than 4. Numerous simulation runs using the Monte Carlo method were performed to check the validity of mapping one-sided link systems into two-sided ones. The simulations were carried out with sequential hunting from a home position in all stages (hunting mode H). Additionally, simulations were performed with sequential hunting from a randomly chosen starting position in the first stage only (hunting mode R). The following section deals with one-sided systems operating in the point-to-point selection mode (PPS-mode), and Chapter 4.3 deals with systems operating in the point-to-group selection mode (PGS-mode).

4.2 Point-to-Point Loss in a One-Sided Link System

The following definition for the point-to-point loss is given /1/.

Upon arrival at an idle inlet, a call suffers a point-to-point loss, if no chain of idle links through the link system can be found, provided at least one outlet of the desired outgoing group is still idle. Only those calls contribute to the arrival rate that find one inlet idle as well as at least one outlet of the desired outgoing trunk group idle.

According to this definition, the point-to-point loss is defined as B_{pp} = lost calls/offered calls.

In /1/ a method to calculate the PP-loss for two-sided systems is presented. As outlined earlier, this method can be applied to one-sided systems after mapping.

In Fig.10, simulation and calculation results for a 4-stage link system are compared to each other. The point-to-point loss B_{pp} is plotted vs. the average traffic per incoming trunk Y/N . PCT1 was offered, and the terminals were wired to 5 groups having 50 trunks each. As it can be seen from the short notation in the figure, system A represents the folded system without extra links. System B is the folded one with extra links. Finally, system C is the two-sided system obtained by mapping. Each simulation result bases on 100,000 calls. It is marked with its 95% confidence interval.

The bold line denotes the loss calculation according to the PPL method /1/.

For reasons of clarity, simulation results with hunting mode R were omitted for systems A and B, because they are only slightly higher than those obtained with hunting mode H. The loss probability of the folded system A with hunting mode

H approximately corresponds to that of the two-sided system with hunting mode R.

As it was outlined in /1/, hunting mode H yields lower losses than does hunting mode R, due to the "push-up" effect. In a folded system, however, the hunting strategy H is different from that one in two-sided systems. Therefore, the occupation patterns of the links are not quite as favorable, as they are otherwise, thus causing slightly higher losses for folded systems. On the other hand, by correctly adding extra links as mentioned earlier the loss probability of a folded system becomes smaller and also closer to that one of the two-sided system with hunting mode H. Many more simulations have certified the validity of this PPL-loss calculation method for one-sided systems.

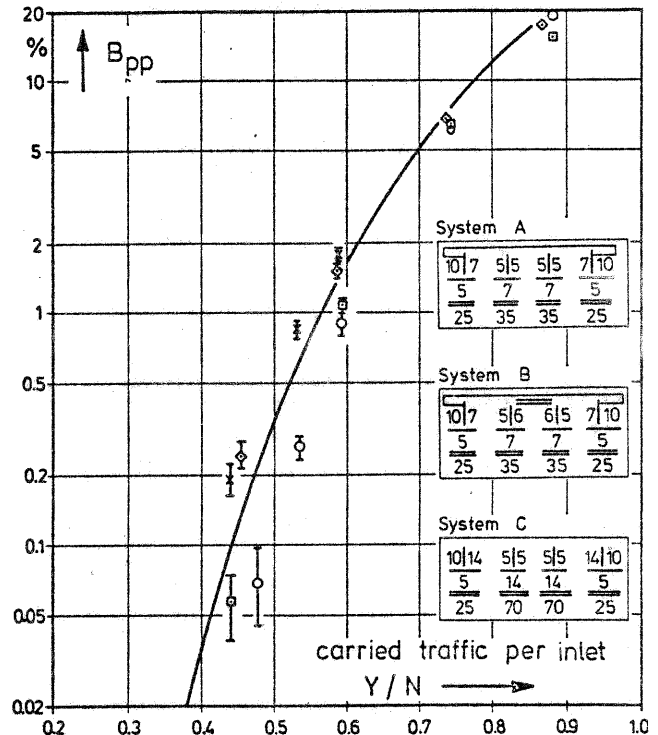

Fig.10: Point-to-point loss B_{pp} vs. carried traffic per inlet Y/N

Simulation: \square folded system A without extra links } hunting mode H
 \square folded system B with extra links }
 \square equivalent two-sided system C hunting mode H
 \square equivalent two-sided system C hunting mode R

PPL calculation: _____

4.3 Point-to-Group Loss in a One-Sided Link System

The following definition of the point-to-group loss is given:

Upon arrival at an idle inlet, a call suffers a point-to-group loss, if no idle trunk of the desired group is accessible. This definition includes also the case where all trunks of the desired group are occupied.

In /3,4/ the method CLIGS for the calculation of loss in link systems with group selection was presented. As outlined earlier, this method can be applied also to one-sided systems, after mapping into two-sided ones.

In Fig.11, simulation and calculation results for another 4-stage link system are compared to each other. The point-to-group loss B_p (r-route) is plotted vs. the average traffic carried per trunk. PCT1 was offered, and the terminals were wired to 5 groups 25 trunks each. The uniform size of the 5 groups has been chosen for this example, in order to achieve a uniform carried

traffic per inlet as well as per outlet. In practice, groups of different size have to be considered. In this case, the individual loss B_r of an outgoing group has to be drawn versus its own carried traffic Y_r/n_r per trunk. Then, the mostly different average carried traffic per inlet Y/N of the link system as a whole which has a significant influence on the effective accessibility, is a fixed chart parameter. The method CLIGS can handle all arbitrary combinations of Y/N and Y_r/n_r .

Analogously to Fig.10, one basic structure in its versions A,B, and C is investigated. The bold line represents the loss calculation obtained by the method CLIGS, and, for comparison, the dashed line denotes the loss of a full accessible group.

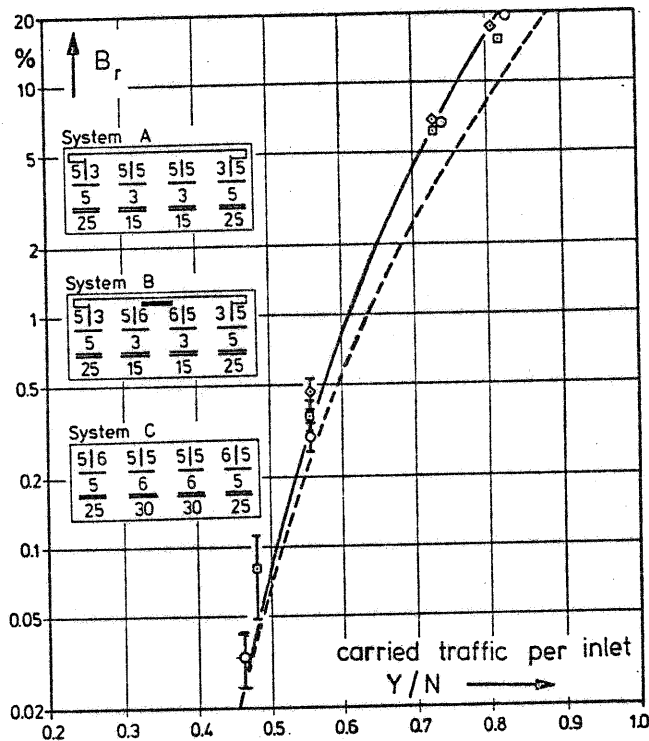

Fig.11: Point-to-group loss B_r vs. carried traffic per inlet Y/N

Simulation: \diamond folded system A without extra links } hunting mode H
 \square folded system B with extra links }
 \circ equivalent two-sided system C }

CLIGS calculation: —————
 Full accessible group: - - - - -

As it can be seen from Fig.11, there is hardly a difference between the three versions. Here, an incoming call can hunt all accessible idle outlets of the desired trunk group ("group selection") and it is not restricted to one single destination multiple. Therefore, omitting the extra links in spite of their theoretical necessity, does not increase the loss significantly.

Also in the case of point-to-group selection, many more simulations have confirmed that the loss of one-sided systems with point-to-group selection can be reliably calculated by means of the method CLIGS in connection with the described mapping method.

5. SYNTHESIS OF ONE-SIDED LINK SYSTEMS

5.1 Systems Operating with Point-to-Point Selection

In /1/, a method is presented to design two-sided link systems by using so-called Nik-Charts for a given number of incoming and outgoing trunks, for a certain carried traffic per inlet and a prescribed loss B_{pp} . This way of designing can directly be applied to one-sided systems. The two-sided system obtained therewith can be transformed into the desired one-sided system by mapping. Two facts have to be given extra attention, i.e. - insertion of extra links (cf. Chapter 3) - k_1 and i_1 must be an even number in the two-sided system because of the mapping. Analogously, the strategies of extending link systems can be applied here, too /1/.

5.2 Systems Operating with Point-to-Group Selection

In /5/, a method is presented to design so-called Optimum Link Systems, i.e. with a number of cross-points per Erlang close to the theoretical minimum, whereas the number of incoming and outgoing trunks N , a certain carried traffic per inlet Y/N , and a system transparency T are prescribed. If the value of T is chosen $\geq 1.2 N$, the internal blocking probability becomes practically zero. All outgoing groups can be calculated like full accessible groups.

Once again, a two-sided system is designed and then mapped into a one-sided system. Attention has to be paid to the above mentioned two facts.

6. ACKNOWLEDGMENT

The authors wish to express their thanks to the Federal Research Association (DFG) as well as to the Federal Ministry of Research and Technology (BMPT) of the F.R. of Germany for supporting these studies for many years. Acknowledgment is also made to Messrs. R. Ertelt and A. Heizmann for their valuable help.

REFERENCES

- /1/ LOTZE, A., RÜDER, A., THIERER, G.: PPL - a Reliable Method for the Calculation of Point-to-Point Loss in Link Systems. 8th ITC, Melbourne, 1976.
- /2/ LOTZE, A., RÜDER, A., THIERER, G.: Point-to-Point Selection versus Point-to-Group Selection in Link Systems. 8th ITC, Melbourne, 1976.
- /3/ BAZLEN, D., KAMPE, G., LOTZE, A.: On the Influence of Hunting Mode and Link Wiring on the Loss of Link Systems. a) 7th ITC Stockholm 1973, Proc. pp 232/1-12. b) Informationsexpress "Informationsübertragung", Moskau, September 1973, Nr.35, S.11-39 (in russisch).
- /4/ BAZLEN, D., KAMPE, G., LOTZE, A.: Design Parameters and Loss Calculation of Link Systems. IEEE-COM 22 (1974) 12, pp 1908-1920.
- /5/ BININDA, N., HOFSTETTER, H.: Die Umkehrgruppierung, eine Gruppierung für moderne, elektronisch gesteuerte Vermittlungssysteme. NTZ 22 (19) H.10, S. 588-596.
- /6/ BOTSCH, D.: Internal and External Traffic and its Effect on the Congestion in Switching Systems. 4th ITC London 1964, Doc. 103.
- /7/ BOWERS, T.L.: Blocking in 3-Stage "Folded" Switching Arrays. IEEE Transactions on Communication Technology, March 1965, pp 14-37.
- /8/ FLEMING, P.: Principles of Switching. Telecom. Engineering Inc., Chesterfield, Missouri, USA.
- /9/ LOTZE, A.: Optimum Link Systems. a) 5th ITC New York 1967, Pre-book pp 242-251. b) Sonderheft Stochastische Prozesse in Bedienungssystemen, Akad.d.Wiss.d.UdSSR, Moskau, 1969, S.49-56 (in russisch).

For further references see /1/.