

PROBLEMS OF SIGNALLING IN INTEGRATED PCM-SWITCHING NETWORKS FOR DATA AND TELEPHONE

Lothar Katzschner and Manfred Witzgall
Institute of Switching and Data Technics
University of Stuttgart
Stuttgart, Federal Republic of Germany

ABSTRACT

In future digital data networks, subscribers have to use an 8-bit alphabet (ITA No.5) for signalling (CCITT Rec.X.1). The multiplexing, transmission, as well as switching of signalling information and data is performed on a bit group (envelope) basis.

Two envelope structures are under discussion by the CCITT:

- a) 8+2 (8 information bits containing one ITA No.5 character and 2 control bits)
- b) 6+2 (6 information bits containing a part of an ITA No.5 character and 2 control bits).

This paper deals with the problem of signalling in the different levels of the data network with special regard to the envelope structures. The necessary equipment for multiplexing, switching, and signalling is described. The problem of common channel signalling vs. data channel signalling is investigated.

The paper concludes with a suggestion for a signalling method for a network, which is partially common for data and telephone traffic - named PINDATE /1/.

1. INTRODUCTION

With the rapidly growing use of PCM transmission systems in the telephone networks, PCM switching will be more and more attractive. One can expect that during the 1980's PCM switching networks will gradually replace the analog networks.

Having a digital network for telephone traffic, it is worthwhile to investigate the possibilities of integrating data services into this digital network (service integration). To establish or to release a call, both data and telephone subscribers have to communicate with the switching network. This communication should be performed in case of data subscribers automatically, i.e. calling and called terminal should work without operating personnel. For this purpose, signalling information between data subscriber and network has to be adapted to the specific demands of data terminals. Therefore CCITT recommends that data terminals have to use ITA No.5 (X.1 /2/) and a special procedure (X.20,X.21 /3,4/) for signalling. During the data phase, however, an arbitrary alphabet may be used. That means, bit sequence independence should be granted.

To distinguish between data and signalling information and for character alignment, status bits and framing bits, resp. are added to each character.

The transmission in the network is done on a bit group (envelope) basis /8/. Two envelope structures are under discussion by the CCITT:

- 8+2 envelope structure. 8 information bits (one complete character) are preceded by one status and one framing bit. The framing bit marks the beginning of a character (alignment bit).
- 6+2 envelope structure. 6 information bits (only a part of one character) are imbedded by the framing and the status bit. But one framing bit is not

sufficient to mark the location of an 8-bit character within the 6+2 envelope. The length of one 6+2 envelope matches with the length of one PCM word, however.

This paper deals with the problem of signalling for data connections in an integrated services digital network (ISDN). The following topics are outlined:
-6+2 and 8+2 envelope structures
-signalling in the different network levels of the switching network
-common channel signalling and data channel signalling
-multiplexing, switching and signalling equipment in the different network levels.

The paper concludes with a suggestion for the signalling procedure in the partially integrated network for data and telephone PINDATE, presented at ISS 74 /1/.

2. MULTIPLEXING SCHEMES FOR DATA CONNECTIONS WITH DIFFERENT BIT RATES (FIG.1)

2.1 Multiplexing Scheme According to X.5C /5/ for a 6+2 Envelope

According to CCITT recommendation X.1 the lowest synchronous bit rate to be transmitted is 600 bps. Using a 6+2 envelope, this bit rate is increased to a bit rate of 800 bps. Therefore, one PCM channel with 64 kbps is divided into 80 subchannels, each with a bit rate of 800 bps. Each subchannel repeats every 80th PCM word. This leads to a superframe of 10ms, which embraces 80 consecutive PCM words, each containing one 6+2 envelope. Data channels with higher bit rates are obtained by combining an appropriate number of subchannels (4 subchannels for 2.4(3.2) and 16 subchannels for 9.6(12.8) kbps). One 6+2 envelope fits exactly into one PCM word.

Subchannels can be switched directly without speed conversion like PCM speech channels.

On the other side the location of one 8-bit signalling character within the 6+2 envelope is not marked by the framing bit because at most 6 bits of one character are transmitted within one envelope. For character alignment a sequence of signalling characters has to be preceded by one or more synchronisation characters (SYN characters).

One character is distributed over 2 PCM words at least which are not adjacent. To reassemble one signalling character, the aggregate bit rate (64 kbps) has to be demultiplexed and the parts of the character have to be buffered until the character is completely received. The time of reassembly in case of a character, transmitted with 600 bps, will be at least one superframe of 10 ms.

2.2 Multiplexing Scheme According to X.51 /6/ for an 8+2 Envelope

Considering the lowest bit rate of 600 bps again, the use of an 8+2 envelope leads to 750 bps. When retaining a superframe with 80 subchannels the aggregate bit rate will be 60 kbps, only. By the addition of extra bits which may be used for subchannel syn-

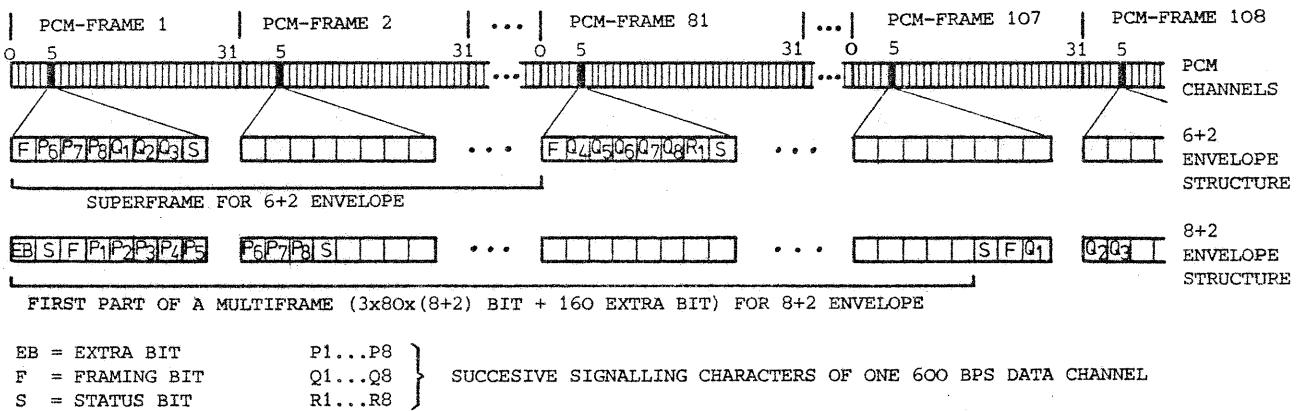

FIG. 1: SUPERFRAME STRUCTURE FOR 6+2 and 8+2 ENVELOPE ACCORDING TO CCITT X.50 and X.51 SHOWN BY THE EXAMPLE OF A 600 BPS DATA CONNECTION

chronisation, this bit rate is again increased to 64 kbps /10,11/. A superframe with 80 subchannels, each containing one 8+2 envelope would comprise, after inserting the extra bits, a non-integer number of $80 \times (8+2) \times 64/60 = 853.33$ bit. Therefore, a multiframe of 3×80 subchannels for transmission within a PCM channel is necessary. Switching can be done after extracting the extra bits and regeneration of the original superframe with 80 subchannels.

One 8+2 envelope is distributed over 2 adjacent PCM words within the channel. Therefore, a signalling character can be directly picked up from the 60 kbps aggregate bit rate. (One character is available after 125 usec, the beginning of a character can simply be derived from the framing bit.)

3. SIGNALLING PROCEDURES IN THE DIFFERENT LEVELS OF THE NETWORK

The lines of demarcation in the different network levels, i.e. between DTE, DCE, CT, DSE, and between DSE's are shown in Fig.2. In the following the characteristics of these lines of demarcation are considered.

3.1 Terminal Signalling

CCITT recommends a standardized interface signalling for asynchronous data subscribers according to X.20 /3/ and for synchronous data subscribers according to X.21 /4/. The interchange circuits between DTE and DCE are shown in Fig.3. Synchronous DTE require signal element timing. To ensure bit sequence independence during the data phase two additional interchange circuits - the control circuit C from DTE to DCE and the indication circuit I from DCE to DTE - are necessary. Byte timing is only optional by CCITT, but should be provided when using an 8+2 envelope (see Section 6).

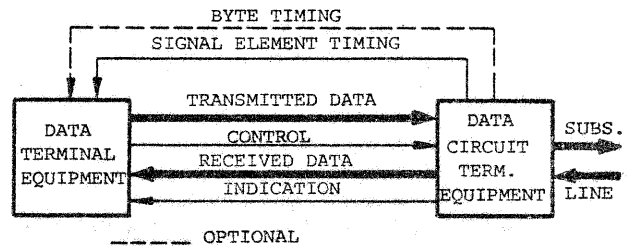

FIG. 3: INTERCONNECTION SCHEME BETWEEN DATA TERMINAL EQUIPMENT (DTE) AND DATA CIRCUIT TERMINATING EQUIPMENT (DCE) ACCORDING TO CCITT X.20 AND X.21 (IN CASE OF X.20 BOLD LINES ONLY)

3.1.1 Signalling Procedure According to X.21 (Synchronous Data Terminals)

CCITT recommends the X.21 interface signalling scheme for call establishment and clearing phase. It is characteristic of the signalling procedure, that signalling information is represented by a sequence of characters on the received and transmitted data circuits and by permanent signals on the control and indication circuits.

3.1.2 Signalling Procedure According to X.20 (Asynchronous Data Terminals)

Signalling is performed in a similar way like synchronous DTE do. As control and indication circuits are not provided, permanent signals of certain duration on the transmitted and received data circuits have to be used for signalisation, i.e. steady "0" is not admissible.

3.2 Subscriber Signalling

3.2.1 Subscriber Signalling for Synchronous DTE

Regarding signalling between DCE and concentrator there exists no recommendation by the CCITT. The terminal signalling interface scheme cannot be applied directly to subscriber signalling because control and indication circuits are not provided. To obtain a simple DCE, it seems to be useful defining a subscriber signalling scheme similar to the terminal signalling scheme.

To ensure bit sequence independence, signalling information has to be marked. For this reason, the information of the control and the indication circuits are represented by a status bit. This leads to an envelope structure on the subscriber line. Both types of envelopes (8+2,6+2) can be applied.

Fig.4 shows a suggestion for the subscriber signalling scheme for call establishment and clearing. Transmitted and received data circuits are directly con-

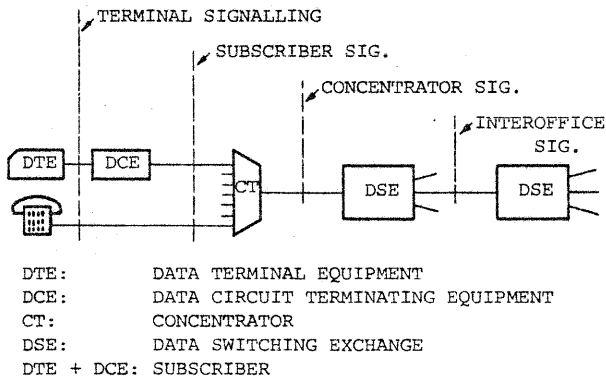

FIG. 2: LINES OF DEMARCATION FOR SIGNALLING IN AN SERVICE INTEGRATED SWITCHING NETWORK

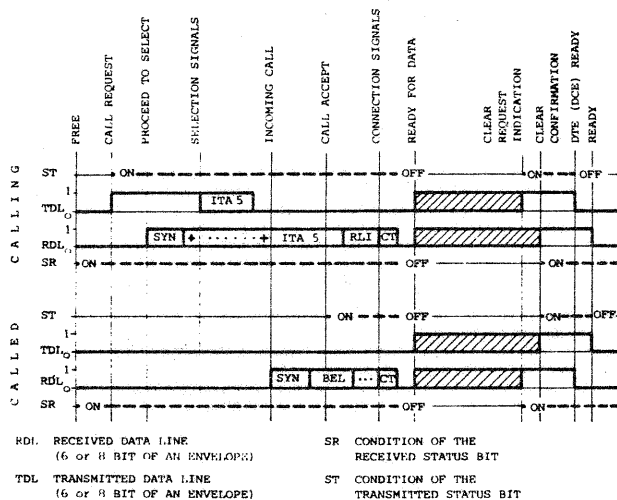

FIG. 4: INTERFACE SIGNALLING SEQUENCE FOR SYNCHRONOUS SUBSCRIBER SIGNALLING

nected through the DCE. The received status bit drives directly the indication circuit; the transmitted status bit is derived from both indication and control circuit.

In networks with 8+2 envelope SYN characters are not provided. Therefore the DCE has to generate these SYN characters.

3.2.2 Subscriber Signalling for Asynchronous DTE

The interface signalling scheme according to X.20 can be directly transferred to the subscriber line. It is also possible to perform an asynchronous to synchronous conversion in the DCE, obtaining a uniform, synchronous subscriber signalling throughout the network

3.3 Concentrator Signalling

Concentrators CT are linked to their data switching exchange DSE via PCM systems, which may be shared with telephone traffic.

Concerning the data traffic the CT may either have only multiplexing functions or it performs a traffic concentration.

In the first case, a permanently switched data channel exists between DTE and DCE. Then the signalling scheme on the subscriber line can be transferred directly to the data channel between DT and DSE.

In the second case, data channels are allocated dynamically to the calling and called subscriber lines. Therefore a common channel signalling should be used at least for transmitting call requests and clear requests. After allocation of a data channel in the CT, selection signals can either be transmitted via the switched data channel or via the common signalling channel.

Asynchronous bit rates have to be converted to synchronous bit rates before transmission from the CT to the DSE and vice versa. The signalling procedure should be adapted to that of the synchronous data subscribers.

3.4 Interoffice Signalling

Interoffice signalling can be done over

- common channels
- switched data channels.

In the latter case, a signalling procedure analogous to concentrator signalling should be applied, e.g. according recommendation X.71 ///. Then no code translation is necessary when signalling characters are transmitted directly to a subscriber.

4. SUGGESTION FOR THE ARCHITECTURE OF MULTIPLEXING AND SWITCHING EQUIPMENTS

4.1 Block Diagram for 8+2 Envelope Structure

Fig.5 shows a solution for the multiplexing, switching and signalling equipment in the concentrator and the data switching exchange.

4.1.1 Concentrator

The concentrator has to multiplex the heterogeneous subscriber bit rates into PCM channels with or without traffic concentration. Hereto three main tasks have to be carried out:

- Speed conversion of all subscriber data rates to a uniform 64 kbps transmission speed ("Data Bursts").
- Insertion of extra bits as shown in Fig.1 and multiplexing of all data channels to one (or more) 64 kbps aggregate bit rates.
- Speed conversion from 64 kbps to the transmission speed of 2048 kbps:

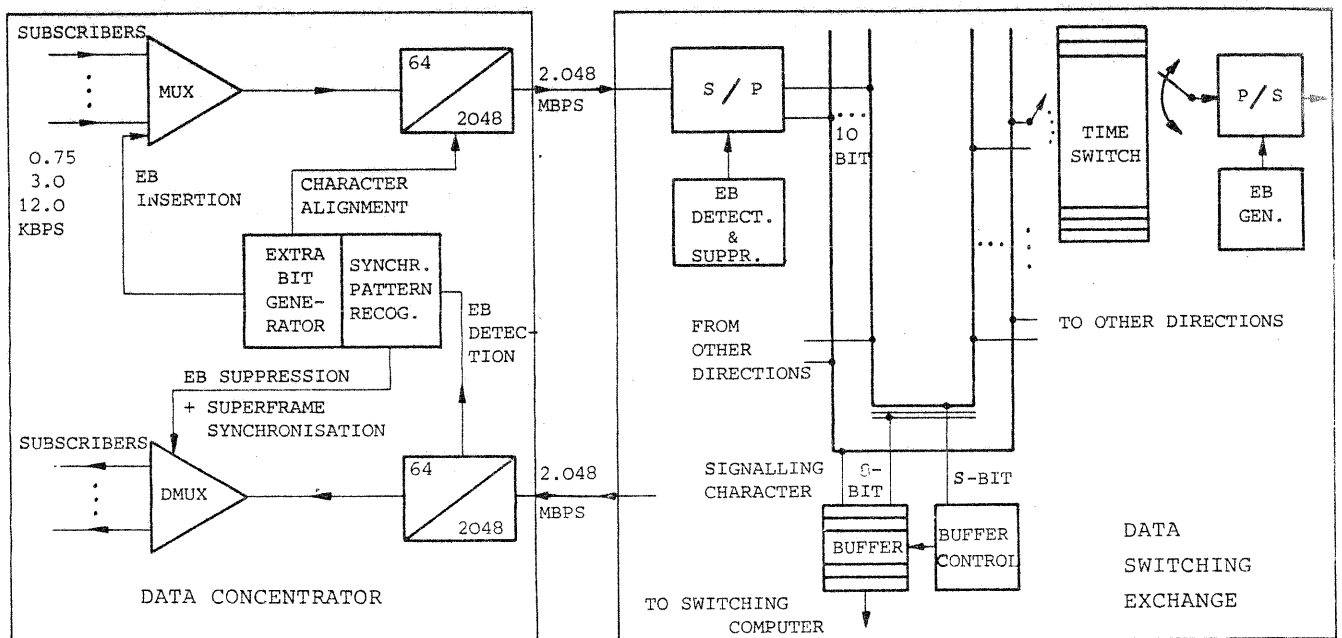

FIG. 5: BLOCK DIAGRAM OF THE MULTIPLEXING, SWITCHING AND SIGNALLING EQUIPMENT IN CASE OF 8+2 ENVELOPES

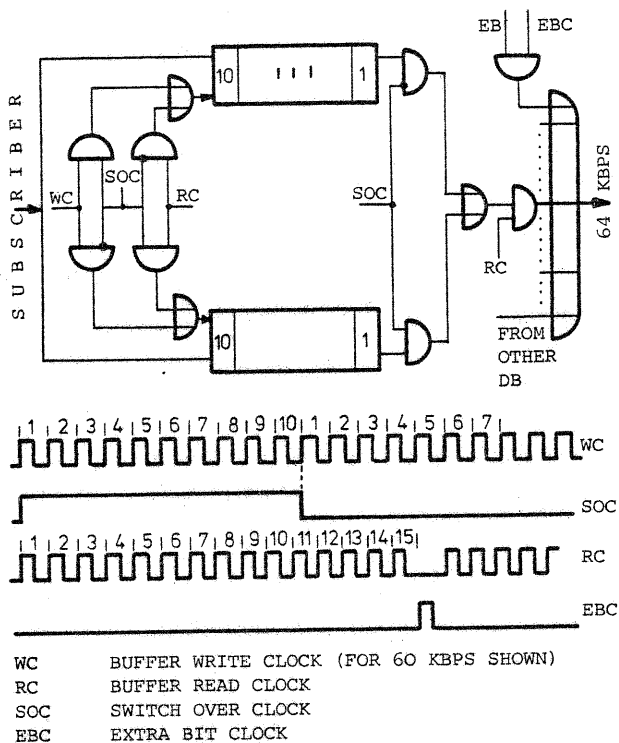

FIG. 6: MULTIPLEXER WITH SPEED CONVERSION FOR DIFFERENT BIT RATES (MUSC) IN ONE CONTINUOUS 64 KBPS BIT STREAM FOR 8+2 ENVELOPES

Fig.6 shows a new concept of a multiplexer with speed conversion (MUSC). To each subscriber one double buffer DB of a MUSC including the switch over logic is associated. The necessary clock supply for the MUSC is shown in Fig.7. The DB write clock WC is provided according to the different bit rates of 0.75, 3, 12, and 60 kbps. The DB has to be switched over, whenever 10 bits (one envelope) have been received. This is done by the switch over clock SOC, derived from the write clock WC.

The subchannel allocation to a data connection is controlled by the eighty word address memory. The address

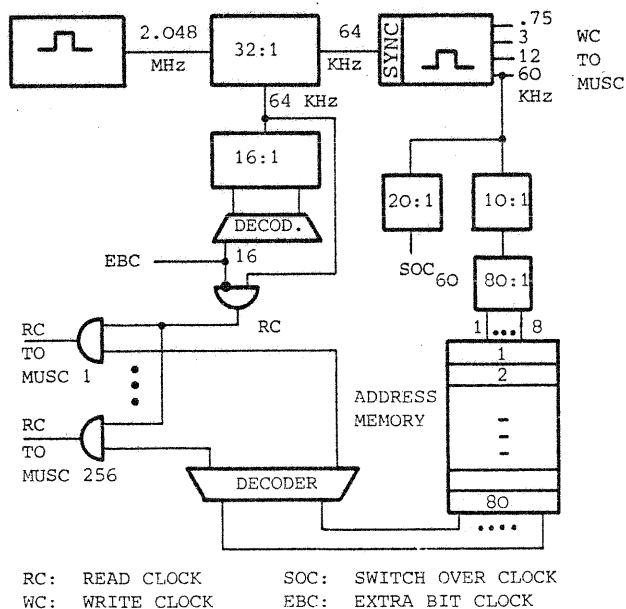

FIG. 7: CENTRALIZED CLOCK SUPPLY AND SELECTION UNIT FOR MUSC

of a DB is stored in this memory one, four or sixteen times depending on the subscriber bit rate. In case of dynamic allocation of data channels (traffic concentration) the address of a DB is not stored in this memory if its subscriber is idle. This address memory is read cyclically and selects the DB by switching the read clock RC to it. The RC is common for all DB's and has a clock frequency of 64 kHz with a gap after every 15th pulse (see Fig.6).

In this gap an extra bit clock EBC inserts an extra bit EB. These extra bits are used for multiframe synchronisation. For this purpose an extra bit generator specifies the pattern of the extra bits.

The 64 to 2048 kbps speed conversion is done similarly by one additional DB as described above. This DB has a length of 8 bits and is switched after 125 us, i.e. after every PCM word. The switch over point has to be chosen in such a way that every second extra bit is in the first bit position of a PCM word (see Fig.1). This facilitates the extraction of extra bits after the transmission considerably.

Speed conversion of the incoming 2048 kbps data stream from the DSE to 64 kbps for the demultiplexer DMUX is done in a similar way. The multiframe synchronisation is performed with the aid of the synchronizing pattern of the extra bits.

4.1.2 Data Switching Exchange

The data switching exchange has to perform:

- The switching of subchannels (8+2 envelopes).
- Extra bit detection and suppression before switching; extra bit insertion after switching.
- Detection, extraction and insertion of signalling characters.

Switching is performed by a time division switch via one internal highway, which carries all incoming data connections. All outgoing PCM channels are connected with this internal highway via time switches.

The extra bits EB which have been added to the 60 kbps aggregate bit rate for transmission within a PCM channel, have to be suppressed in order to reestablish the original 8+2 envelope structure. After the switching of the envelopes the extra bits have to be inserted again.

To achieve a fairly low speed of the internal highway a series to parallel conversion (S/P) and vice versa is applied at the incoming and outgoing PCM channels, resp. Thus, a 10 bit parallel switching is performed. Besides this conversion, the S/P and P/S converters suppress and insert the extra bits as mentioned above.

A signalling character detection unit is simply switched to the internal highway and activated by the status bit. The characters marked by the status bit are extracted and stored in the buffer. The buffer contents can be transferred to the switching computer at fixed time intervals.

The buffer size depends on the expected number of simultaneously signalling subscribers and on the maximum transfer rate to the switching computer. Traffic investigations lead to a buffer size of about 15 locations, if the call rate amounts to 30 calls per second and a buffer overflow of one character per 10 years is admitted.

4.2 Block Diagram for 6+2 Envelope Structure with SYN Characters

Fig. 8 shows a solution for the multiplexing, switching and signalling equipments in the concentrator and in the data switching exchange.

4.2.1 Concentrator

It has the same basic functions with regard to multiplexing as in the case of 8+2 envelopes. However, there is no need of inserting extra bits, because the

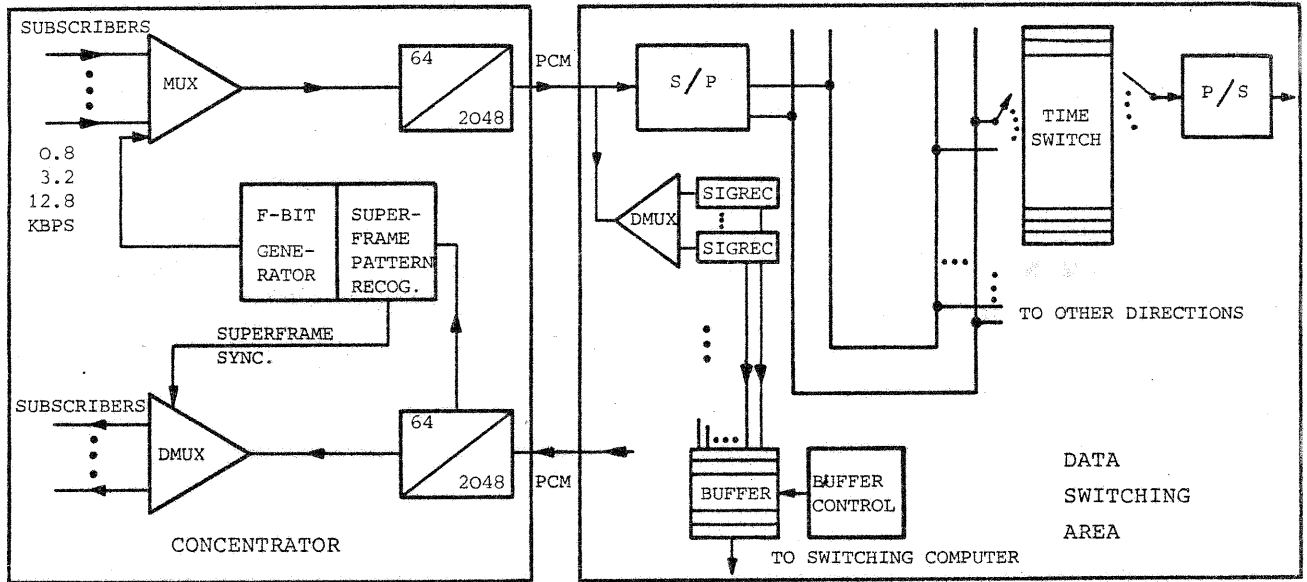

FIG. 8: BLOCKDIAGRAM OF THE MULTIPLEXING, SWITCHING AND SIGNALLING EQUIPMENT IN CASE OF 6+2 ENVELOPES

aggregate bit rate of the 80 subchannels is 64 kbps and fits exactly into one PCM channel. The framing bit of an envelope is necessary on the subscriber line to mark the position of the status bit. As within one PCM channel the position of the status bit is defined by the PCM word, the framing bit will now be used for the synchronisation of the 10 ms superframe. The 64 to 2048 kbps speed conversion is done by double buffers again, in such a way that one 6+2 envelope fits exactly into one PCM word.

4.2.2 Data Switching Exchange

Two main tasks have to be performed:

- The switching of subchannels (6+2 envelopes).
- Detection and extraction as well as insertion of signalling characters.

Switching of subchannels can be done similarly to the case of an 8+2 envelope. However, data channels are switched as 8-bit PCM words just like telephone speech channels

One signalling character is distributed over at least two PCM words which are not adjacent in the case of lower speeds than 48 kbps (see Fig.1). The extraction of signalling characters requires special signalling receivers SIGREC. Each SIGREC must have registers to reassemble the signalling characters. In Fig.9 a signalling receiver SIGREC is depicted. SIGREC's are only switched to the data channels during the signalling phase.

A SIGREC address memory contains the allocation of each SIGREC to its data connection (to 1,4 or 16 subchannels, resp.). Whenever the address of a SIGREC is read out of the memory, the 6 information bits in the PCM word (one envelope) are shifted in the addressed register. Thus the bit sequence of each signalling subscriber passes through a SIGREC register. This bit sequence is permanently checked for SYN characters. Detecting a SYN character, an individual 3-bit counter is synchronized which performs the 8-bit character alignment. All received signalling characters are multiplexed again and transferred via a buffer to the switching computer.

4.3 6+2 Envelope Structure with Multiframe

Besides using SYN characters for signalling character alignment, an option of X.50 exists which uses a 4-octet group for character alignment, see Fig.10.

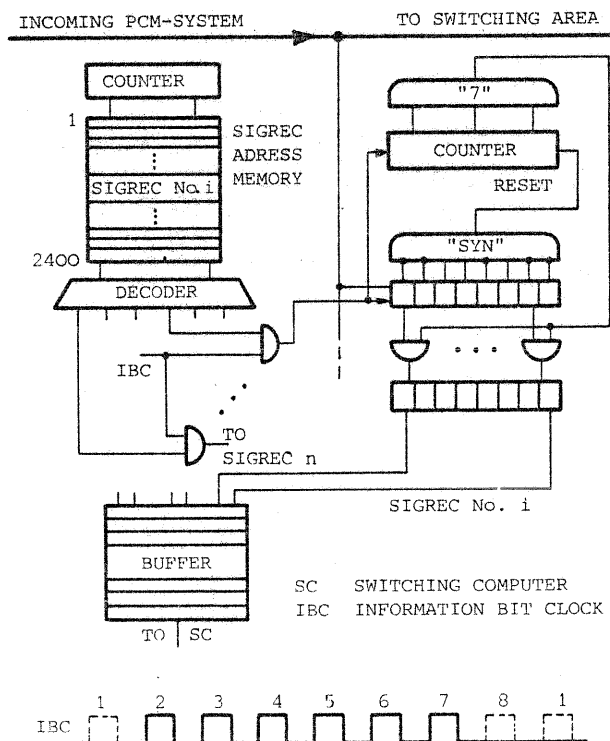

FIG. 9: SIGNALLING CHARACTER RECEIVER (SIGREC) WITH CENTRALIZED CONNECTION UNITS TO A PCM-SYSTEM AND TO THE SWITCHING COMPUTER (SC) RESP, FOR 6+2 ENVELOPE

F	P1	P2	P3	P4	P5	P6	S	Type A
F	P7	P8	Q1	Q2	Q3	Q4	S	Type B
F	Q5	Q6	Q7	Q8	R1	R2	S	Type C
F	R3	R4	R5	R6	R7	R8	S	Type D

P1-P8, Q1-Q8, R1-R8 8-bit characters

FIG. 10: The 4-OCTET GROUP

One 4-octet group contains three 8-bit characters and 4 status and 4 framing bits. (For signalling, however, 3 status bits would be sufficient.) In every fourth PCM word of one data connection (e.g. for a 600 bps connection in every 4x80=320th PCM word of a PCM channel) the first bit of a signalling character is adjacent to the framing bit F. One signalling character is distributed over exactly two PCM words, again not adjacent for bit rates less than 48 kbps. Therefore, the reassembling of signalling characters is necessary again.

For character alignment two possibilities are under discussion /12/:

1. Four superframes, each with 80 subchannels are combined to one multiframe which embraces 320 octets. For all data connections the first PCM word (octet) within this multiframe is one of Type A (see Fig.10). The beginning of the multiframe is defined by the sequence of framing bits F. For the multiplexing of the subscriber bit rates an individual synchronisation of the multiframe is necessary.

This can either be done

- by buffering a whole 4-octet group per data connection which leads to a considerably delay time, or
- by reconfiguring the 8-bit characters individually per data connection and regrouping them according to a uniform multiframe structure by the multiplexer.

The 64 kbps aggregate bit rates within incoming PCM channels in a data exchange usually are not synchronous concerning the position of the multiframe. Therefore one of the two above mentioned multiframe synchronisation means has to be performed before switching. The 2nd method should be preferred as it does not lead to additional delay times. All outgoing PCM channels are synchronous concerning the position of the multiframe. If reconfiguration of the 8-bit characters is done for the purpose of switching, the detection of signalling characters should profit from the 8-bit presentation of the characters. Then signalling character detection will be similar to the case of using 8+2 envelopes /12/.

2. No multiframe is provided. Therefore the beginning of a 4-octet group has to be marked individually for each data connection. This could be done e.g. by using the fourth status bit /12/. In this case multiplexing of the subscriber rates and switching of data connections can be performed similarly to the case of 6+2 envelopes with SYN characters. Again signalling characters have to be reassembled. For this purpose signal receivers (similar to SIGREC see Fig.9) are necessary. The beginning of signalling characters is determined not by SYN characters but by the position of the characters in their 4-octet group.

5. DATA CHANNEL SIGNALLING VERSUS COMMON CHANNEL SIGNALLING

The problem of using the individual data channel or a common channel for signalling has to be investigated separately for

- concentrator signalling and
- interoffice signalling.

5.1 Concentrator Signalling

As already mentioned in Section 3.3 data subscribers can be switched via the concentrator CT either permanently or temporarily (i.e. only during the data connection) to the data switching exchange DSE. In the first case, signalling characters to and from the subscriber line can be transferred through the concentrator CT.

In the case of temporarily switched data channels, at least the call requests have to be transmitted via a common signalling channel to the DSE, so that a data channel can be switched from CT to DSE.

If, however, a common channel is available - possibly shared with signalling information of telephone subscribers - all signalling of the data subscribers could be done via this common channel. In this case the bit rate of this common signalling channel should be high enough to ensure no significant delay and to keep the amount of buffers small. If only one PCM channel is used for common channel signalling the above quoted demand can practically not be fulfilled in case of 9.6 or 48 kbps data subscriber signalling /13,14/. So, a hybrid signalling method seems to be preferable: call and clear requests should be transmitted over the common channel, all other information (selection signals, remote line identification, etc.) via the switched data channel.

5.2 Interoffice Signalling

5.2.1 Data Channel Signalling DCS

According to CCITT recommendation X.71, signalling information between DSE's is interchanged over the switched data channels. Signalling is done in a similar way as subscriber signalling using the same alphabet. The seizure of an incoming data channel must be detected in the DSE. Therefore signal receivers must be connected permanently to the incoming interoffice PCM channels used for data.

Signalling character sequences, e.g. remote line identification RLI, can be transmitted without any conversion through the network to both subscribers.

5.2.2 Common Channel Signalling CCS

As already mentioned in Section 5.1, the common signalling channels must have a high transmission rate to grant a short delay time for the signalling interchange between DSE's. Then shorter call set up times especially for the low speed connections can be obtained by the CCS. Using CCS, only one centralized signal receiver is necessary for each common channel.

CCS provides a high flexibility concerning coding of signalling information, procedures for signalling information interchange, transmission speed and means of error detection and correction. Furthermore, the interchange of network management, control and maintenance information requires a common channel. On the other hand, continuity checks of the switched data channels have to be performed because signalling information is not interchanged via the switched data channel.

5.3 Comparison of the Interoffice Signalling Methods

The use of CCS or DCS, resp. depends among others on the multiplexing scheme used for transmission of the subscriber bit rates.

In case of 6+2 the signalling receivers are considerably complicated compared with the case of 8+2. Therefore, data channel signalling DCS seems not to be useful, because each data channel requires one signal receiver permanently.

Using 8+2 both methods, CCS and DCS, require a comparable amount of signalling equipment. Nevertheless, CCS should be provided because of the above mentioned advantages. This leads to the following conclusion:

For both multiplexing schemes, 6+2 and 8+2, CCS should be preferred for signalling information interchange by DSE's. Signalling information interchange between DSE's but destined for the subscribers (i.e. remote line identification) should be transmitted directly via the switched data channel.

ENVELOPE STRUCTURE		8+2 (CF.4.1)	6+2 WITH SYN (CF.4.2)	6+2 WITH MULTIFRAME (CF.4.3)
MULTIPLEXING	channel bearer rates	0.75,3,12,60 kbps	0.8,3.2,12.8,64 kbps	0.8,3.2,12.8,64 kbps
	aggregate multiplex bitrate of a super-frame with 80 sub-channels	60 kbps	64 kbps	64 kbps
	function of the F-bit	character alignment	superframe synchronisation	multiframe synchronisation
	function of extra bits	multiframe synchronisation (4 kbps)	no extra bit necessary	no extra bit necessary
	frame structure of the 64 kbps aggregate bit rate	multiframe with 3 super-frames (3x80 envelopes with 8+2 bit, 160 extra bit)	superframe (80 envelopes with 6+2 bit), no multi-frame necessary	multiframe with 4 super-frames (4x80 envelopes with 6+2 bit)
	taking into account the character structure	yes	no	yes
SWITCH.	switching of 8 bit characters	yes (after extra bit suppression)	no	no
	terminal signalling according X.21	no, byte timing instead of SYN characters should be provided	yes	no, byte timing instead of SYN characters should be provided
SIGNALLING	bit sequence independence	yes	yes	yes
	signalling character alignment	by detecting F-bits	by detecting SYN characters	by detecting the position of a character in the multiframe
	signalling equipment	one centralized signal receiver permanently scanning all data channels	several decentralized signal receivers, either a) permanently switched to each data channel b) temporarily switched to signalling data channels only	similar to 6+2 with SYN
	signalling after entering the data phase	yes	yes in case of a) no in case of b)	similar to 6+2 with SYN

Table 1: COMPARISON OF THE MULTIPLEXING SCHEMES

In case of 6+2 this leads to synchronizing problems. The signalling character alignment between the far destined DSE and the called subscriber (established by a sequence of SYN characters) is not known in the DSE of the calling subscriber. Therefore, signalling characters from the DSE of the calling subscriber have to be preceded by SYN characters.

In case of 8+2 character alignment is performed by the aid of the framing bits throughout the network.

6. COMPARISON OF THE MULTIPLEXING SCHEMES

In Table 1 the 3 discussed multiplexing schemes are compared with regard to their multiplexing, switching and signalling characteristics. If recommendation X.21 is modified (byte timing instead of SYN characters) the 8+2 multiplexing scheme seems to be the optimum solution. Outstanding characteristics are

- uncomplicated signalling character detection
- signalling after entering the data phase with no additional equipment
- character alignment during the data phase of two DTE's by the byte timing, derived from the received framing bit.

If using X.21 without byte timing, a 6+2 multiplexing scheme within the network is most suitable because it is adapted optimally to this interface signalling scheme.

6+2 with multiframe has the same disadvantages concerning signalling character detection. Moreover, it

has additional difficulties with regard to multiframe synchronisation before switching.

7. SIGNALLING IN THE "PARTIALLY INTEGRATED NETWORK FOR DATA AND TELEPHONE" PINDATE

Fig.11 shows the block diagram of the partially integrated network for data and telephone PINDATE /1/. Data and telephone subscribers are connected with remote concentrators. The control of the concentrator and the PCM transmission systems are commonly used. In the local telephone exchange data traffic is extracted from the incoming PCM systems and routed to a local data concentrator. Here the data traffics are separated according to their bit rates, concentrated and inserted in outgoing PCM channels. Each of these PCM channels carries only data connections with the same bit rate. Data traffic is transmitted again together with telephone traffic to the junction telephone exchange. There all incoming PCM channels for data are not switched but only multiplexed to PCM systems, carrying data traffic only. The separation of the different bit rates into individual PCM channels is maintained. These PCM systems lead to the first data switching exchange (DSE 1) at the level of the telephone main exchange. This DSE 1 is the first data switching point in the network. It performs also charge metering of the data calls. Furthermore, it has major control functions for the establishment and clearing of both, local and toll data connections.

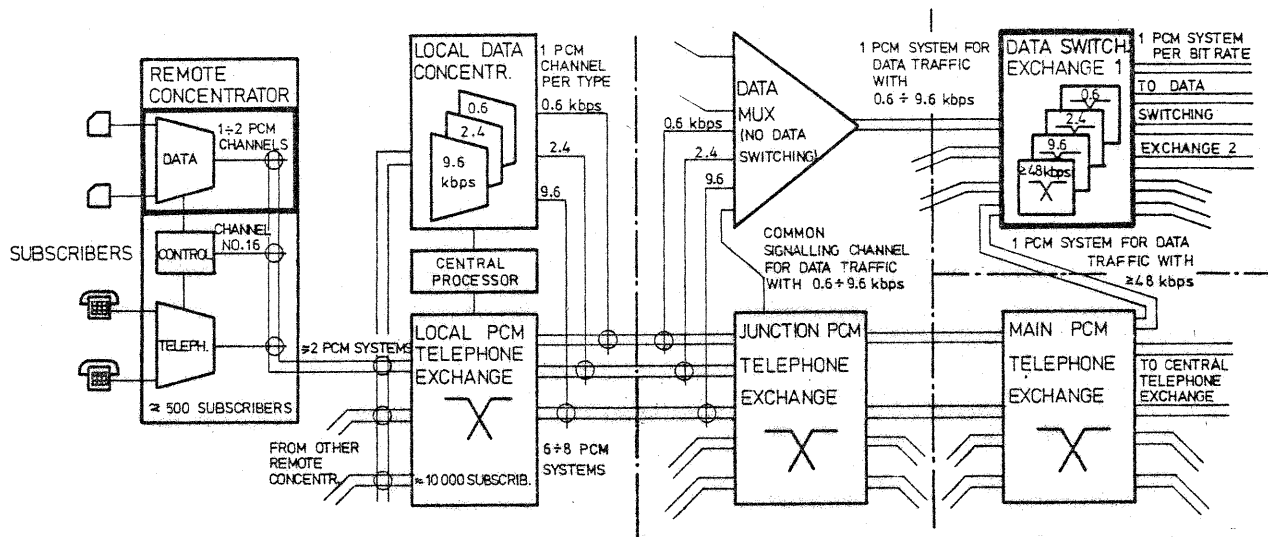

FIG.11: THE PARTIALLY INTEGRATED NETWORK FOR DATA AND TELEPHONE (PINDATE)

In the next higher level the data switching exchange 2 (DSE 2) acts as a toll switching center only. Switching in the DSE 1 and DSE 2 is performed separately for data and telephone traffic.

Throughout the network an 8+2 multiplexing scheme will be applied. The principle of switching, multiplexing, and signalling therefore has already been described (Section 4.1, Fig.5). Data concentrator and data switching exchange DSE 1 according to Fig.5 are bold-bordered in Fig.11.

7.1 Terminal Signalling, Subscriber Signalling

A modification of X.21 will be applied, and byte timing will be implemented instead of SYN character transmission. Repeating of signalling characters (e.g. the character "+" for proceed to select or the character "BEL" for incoming call) is not provided. For DTE's with the unmodified X.21 and for asynchronous DTE's special DCE's will be available. The status bit and the framing bit are defined as described in Sect.3.2.

7.2 Concentrator Signalling

In the concentrator speed conversion of the subscriber bit rates, and multiplexing to a PCM channel is performed. This is done by the MUSC as shown in Fig.6. (Asynchronous bit rates are converted to synchronous bit rates before multiplexing.) Call and clear requests are detected in the remote concentrator. They are transmitted under the control of the local and junction telephone exchange via common signalling channels to the DSE 1. The establishment of a data channel from concentrator to the DSE 1 is supervised by the local telephone exchange. Proceed to select signal, incoming call signal, etc. are fed into the switched data channel by the DSE 1. Selection signals are transmitted via the switched data channel, too, and extracted in the DSE 1.

7.3 Interoffice Signalling

Routing and further control informations between DSE's are interchanged via 64 kbps common signalling channels. The format of the signalling information is adapted to the 8 bit PCM word structure of the common channel and consists of a sequence of PCM words. Moreover, signalling information destined for subscribers (e.g. RLI, "connected") can be transmitted over the switched data channel via one or two DSE 2.

ACKNOWLEDGEMENT

The authors wish to express their thanks to Prof. Dr.-Ing. A. Lotze, Director of the Institute of Switching and Data Technics, University of Stuttgart, for supporting this work.

This work was supported by the Federal Ministry of Science and Technology of the Fed. Rep. of Germany and the German Research Society.

REFERENCES:

- /1/ BAZLEN, D., KATZSCHNER, L., LÖRCHER, W., WEISSCHUH, H.: Data Switching in an Experimental PCM Switching System. ISS 74, Munich 1974, paper 233.
- /2/ CCITT, Rec. X.1
- /3/ CCITT, Rec. X.20
- /4/ CCITT, Draft Rec. X.21
- /5/ CCITT, Study Group VII, Contr.271 (Rec.X.50)
- /6/ CCITT, Study Group VII, Contr.272 (Rec.X.51)
- /7/ CCITT, Study Group VII, Temp.D.43-E (Rec.X.71)
- /8/ FICK, H.: Structures and Operating Principles of Networks for Data Traffic. ICC 74, Stockholm 1974, paper W 1210.
- /9/ BENOWITZ, P., BUTTERFIELD, S.J., CICHETTI, M.P., CROSS, T.G.: Digital Data System, Digital Multiplexer. BSTJ 54 (1975) 5, 893-918.
- /10/ BOTHNER-BY, H., PALONEN, V., SJÖSTRÖM, O., SVENDSEN, H.: Study of Public Switched Synchronous Data Networks for the Nordic Countries. Tele (1975) 1, 10-17, 48.
- /11/ SHIMASAKI, N., KOHASHI, T., HABARA, K., SUZUKI, Y.: A Compatible Multiplexing Technique for Asynchronous and Isochronous Digital Data Traffics. IEEE Trans. Com. 23 (1975) 11, 1315-1321.
- /12/ DAVANCES, M., TEXIER, A.: Une Maquette de Commutateur de Données Synchrones. Commutation et Électronique 52 (1976), 38-50.
- /13/ KATO, M., IKEDA, H.: An Experimental Digital Data Switching System DDX-1. ISS 74, Munich 1974, paper 232.
- /14/ KURAHASHI, K., KUNIHICO, T., NISHIMURA, Y.: Signalling Method in a Digital Switching System. ISS 74, Munich 1974, paper 235.